

2022



# Specialist in commercial fridge and freezer door seals

[www.dsu-nl.com](http://www.dsu-nl.com)



In-house  
production



Extensive  
product range



Order from  
1 piece



Always a  
fitting solution



Support with selecting  
the correct profile



Fast  
delivery

## DSU Sales UK & Ireland

☎ 0330 027 1648

## DSU Production

Neutronenlaan 1  
5405 NG Uden  
The Netherlands

☎ +31 413 264 472

✉ [sales@dsu-nl.com](mailto:sales@dsu-nl.com)













🌐 [www.dsu-nl.com](http://www.dsu-nl.com)

📞 +31 6 30 50 3000

WhatsApp



# Index

Illustrations explained	2
About us	3
Replace a seal in 4 steps	5
Maintenance	9
 Dart profiles with magnet	10
 Dart profiles, large dart with magnet	16
 Dart profiles without magnet	20
 Lip profiles with magnet	22
 Flap profiles with magnet	24
 Compression profiles without magnet	26
 Profiles which can be counter-welded	28
 Profiles made of special compounds	30
 Silicone profiles	34
 Rubber profiles	36
 Rubber sweeper profiles	41
 EPDM: Neoprene sponge rubber and foam profiles	44
 Magnets and Retainingstrips	45





### Instructions for using the illustrations

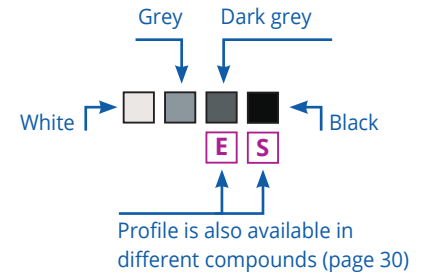
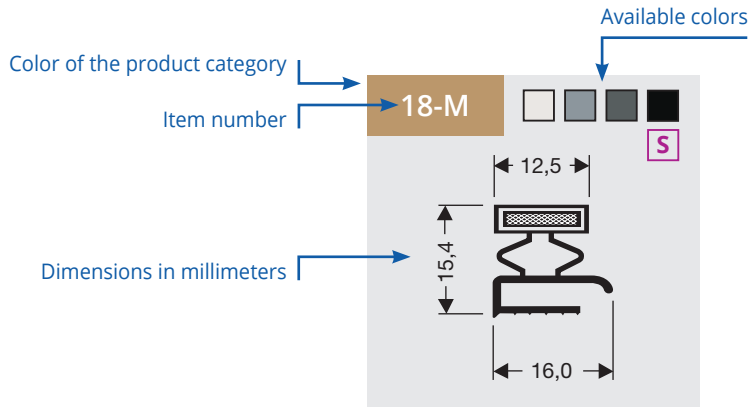

Place a profile cross-section in the upper left corner and take a picture. Send the picture via WhatsApp, email or upload via the website.



**WhatsApp**  
**+ 31 6 30 50 3000**

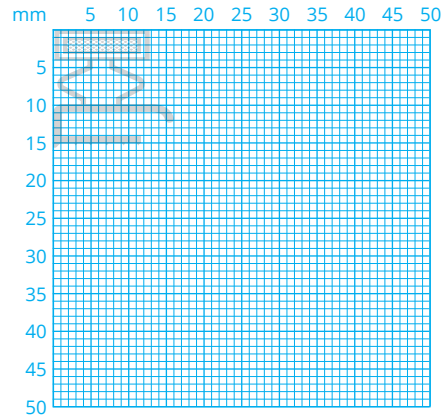

**All profile drawings in the catalog are shown on the scale 1:1.**



## About us



Since the start, in the 1970's, DSU has grown to become a company specialized in the manufacturing of bespoke refrigerator and freezer seals for commercial refrigeration equipment.

With our products we serve commercial refrigeration and kitchen maintenance companies. We also deliver our (magnetic) seals to refrigeration equipment manufacturers and spare parts dealers.

### **Always a suitable solution**

*"Always a suitable solution"* that is our goal. With over 220 different seal profiles available from stock. DSU is the leading manufacturer of bespoke refrigerator and freezer seals on the European market.

Are you unable to find the profile you are searching for or do you have any doubts about the matching profile? Send us a photograph of the cross section via email or WhatsApp. We are glad to help you find the right profile or a suitable alternative.

### **Search by brand**

An overview with the seal profiles used by brand you can find on our website.

### **Fast delivery**

We have our own in-house manufacturing department. This enables us to manufacture bespoke seals fast. Our regular lead-time is 2 – 4 working days.

Express orders are shipped the same day if received before noon (CET). Express orders are subject to a surcharge with a maximum of 10 seals per order.

### **Quality**

Competent employees manufacture bespoke seals with utmost care and precision so they will fit perfectly in the door or drawer. We exclusively utilize materials from approved suppliers. The chance of a manufacturing defect is reduced to an absolute minimum through our quality assurance system.

### **Serial production**

Large numbers of seals (50+) with similar dimensions we can mass produce at attractive prices. Contact our sales department with your inquiry.

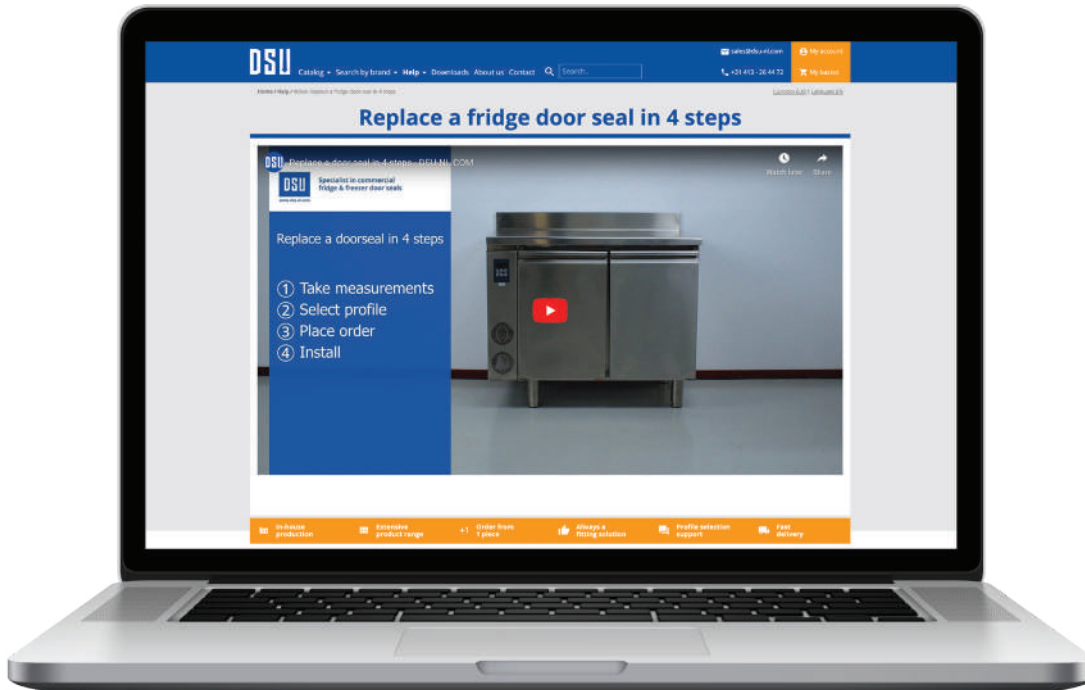

Watch the instructional videos on our website

Copyright 2022 DSU BV  
September 2022

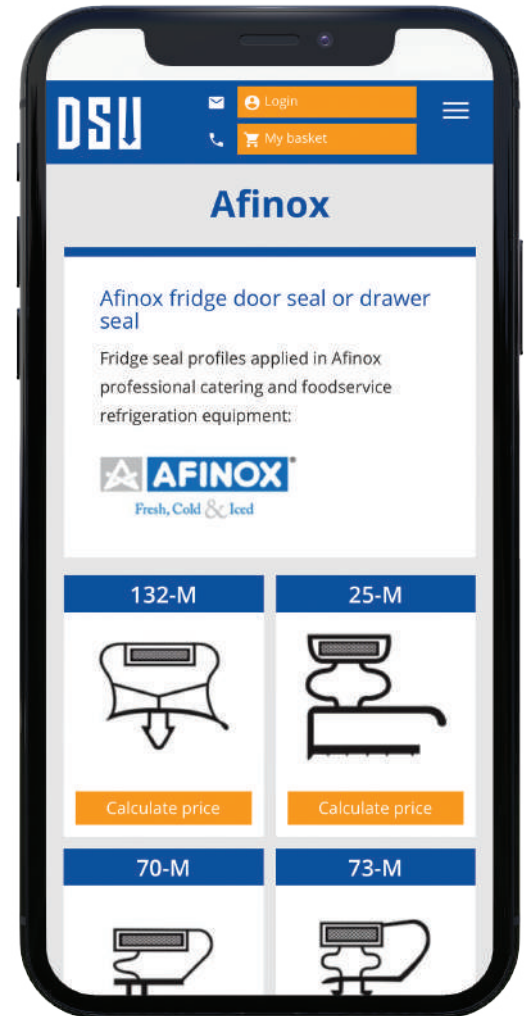

Profiles overview by brand

# Replace a seal in four steps

- ① Take measurements
- ② Profile selection
- ③ Order
- ④ Installation



See instructional videos on our website under "help" or scan the QR code

## ① Take measurements



Taking correct measurements is important when ordering made-to-measure door seals. There are three methods to determine the seal measurements.

- A size (Outside-to-Outside)
- B size (Magnet-to-Magnet)
- C size (Dart-to-Dart)

### A size

The outside-to-outside measurements (A size) are most commonly used to determine the fridge seal dimensions (width x height). A size example, see page 23. We advise to take outside-to-outside measurements while the seal is still fitted in the door or drawer.

The A size can be applied for any type of fridge seal.

### B size

Magnet-to-Magnet (B size) is measured from outside of the seal magnet to outside of the seal magnet on the opposite side. This method is not commonly used.

### C size

For push-in (dart type) profiles we advise to take the dart-to-dart (C size) measurements. C size example, see page 19. This is commonly referred to as the centreline measurements. In practice this means you measure inside the door or drawer from the inside edge of the slot on one side to the outside edge of the slot on the other side.

This is the preferred method because it gives the most precise measurements.

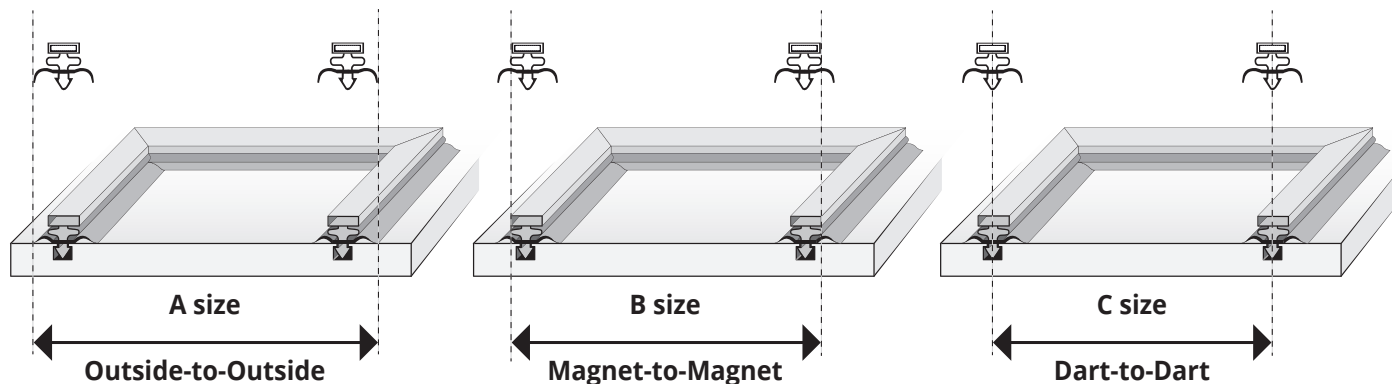

## ② Profile selection

Identify the seal profile with the fridge seal cross-section. You can see the cross-section by cutting the seal at the top side using scissors or a craft knife.

If you know the equipment brand you can find all the profiles used by brand on our website. Brand not known? Compare the cross-section with the drawings (scale 1:1) in our catalogue or use our professional sample case.

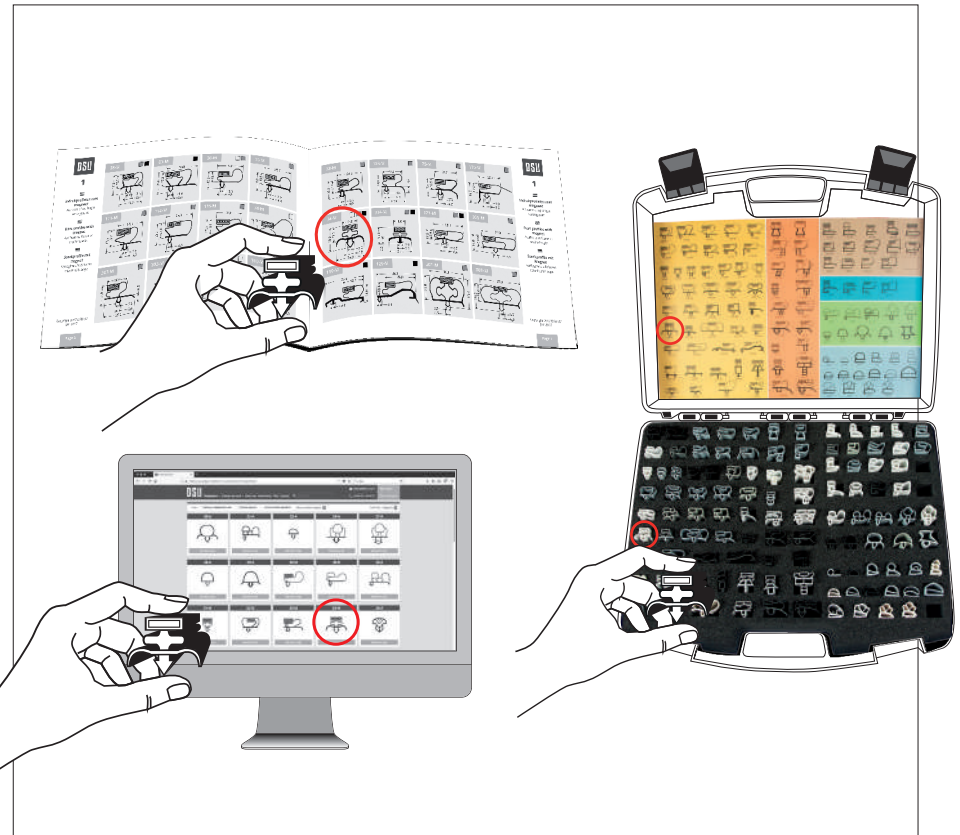
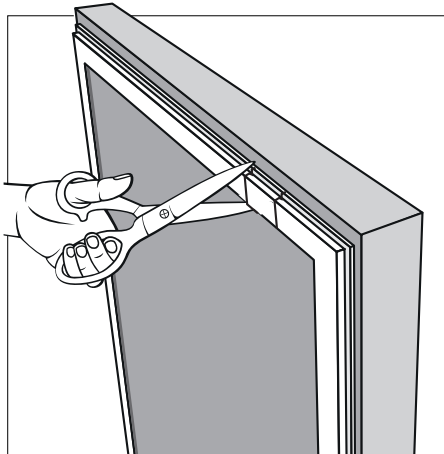

### *Professional sample case*

We have compiled a professional sample case for engineers. The sample case contains over 100 of the most commonly used seal / gasket profiles. This sample kit can be ordered on our webportal.





Are you unable to find the profile you are searching for? Or do you have any doubts about the matching profile? Send us a photograph of the cross-section via WhatsApp (+31 6 30 50 3000), email or through our website [www.dsu-nl.com](http://www.dsu-nl.com). We are glad to help you find the right profile or a suitable alternative.

It is also possible to send a cross-section of the seal by post along with our order form. The order form can be found on our website.

[www.dsu-nl.com/en-EU/downloads](http://www.dsu-nl.com/en-EU/downloads)



### ③ Order

Use our online seal configurator for the easy composition of a bespoke fridge seal.  
[www.dsu-nl.com](http://www.dsu-nl.com)

- E-mail [sales@dsu-nl.com](mailto:sales@dsu-nl.com)
- Fax +31 413 269 068
- Mail *Neutronenlaan 1, 5405 NG Uden, The Netherlands*
- Phone +31 413 264 472

The screenshot shows the DSU website's online seal configurator for the '34-M' profile. The page includes a navigation bar with 'DSU Catalog', search, and account options. The main content area displays the product name '34-M' and a list of compatible brands: Cool Compact, eisfink, FOSTER, HOBART, kampri, Rieber, smeva, RGT, and GROMO.com. The configuration options are divided into several sections:
 

- Composition:** '4 sides - 4x magnet' (selected), with an option for 'Strong magnet'.
- Measurement method:** 'A size (Outside-to-Outside)' (selected), 'B size (Magnet-to-Magnet)', and 'C size (Dart-to-Dart)'.
- Color:** Three color swatches are shown.
- Measurements:** 'short side' is 58.6 cm and 'long side' is 61.8 cm. A diagram shows a rectangular seal with these dimensions.
- Reference:** 'Foster Counter' is entered in the field.
- Summary:** Shows a diagram of the seal and lists specifications: '4 sides - 4x magnet', 'C size (Dart-to-Dart)', 'Black', and '61.8 cm x 58.6 cm (length x width)'. Pricing is shown as 'Per piece EUR 0,00', 'Quantity 1', 'Sub total EUR 0,00', and 'Total amount EUR 0,00'.
- Quantity:** A slider is set to '1'.
- Buttons:** 'View true size', 'Back to overview', and 'Add to cart'.

 The bottom of the page features a blue banner with the text 'Do you need help? We are happy to help' and several service icons: 'In-house production', 'Extensive product range', 'Order from 1 piece', 'Always a fitting solution', 'Profile selection support', and 'Fast delivery'.

## ④ Installation



### Before installation

- Take the seal from the box upon receipt.
- Always hold the seal by its corners to keep the magnetic strip from breaking.
- Lay down and unfold the seal.
- Allow the seal to reach the ambient temperature
- Wrinkles and creases (caused by transportation or storage) can be removed by gently warming the seal with a blow-dryer or heat gun.
- Gently remove the old seal from the door or drawer.
- Clean the door or drawer tracking and cabinet face thoroughly. Use a clean cloth and professional fridge seal cleaner.
- Disinfect the door or drawer tracking and cabinet face with an approved disinfectant. Let it sit for 30 seconds and wipe dry with a clean cloth before placing the new seal.

### Installation

- Place the corners of the seal first followed by the short and long sides, this to keep the seal from stretching.
- With push-in (dart) seal profiles: check all the way around if the seal is fully secured in the tracking.
- Remove any creases or cracks by gently warming the seal with a blow-dryer or heat gun.

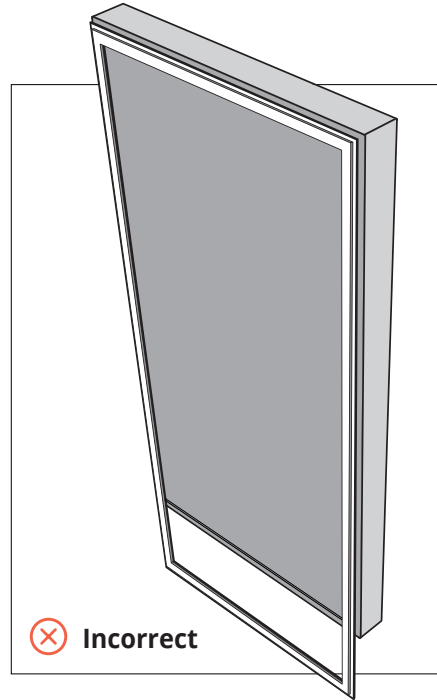

- Directly after installation a magnetic seal can have less power of attraction. It can take several weeks for the magnet to reach its optimal power of attraction.
- In case a corner breaks during installation this can be repaired by using superglue.

### Check the following points in case the seal does not seal the fridge correctly after installation

- Are the profile and measurements ordered correctly?

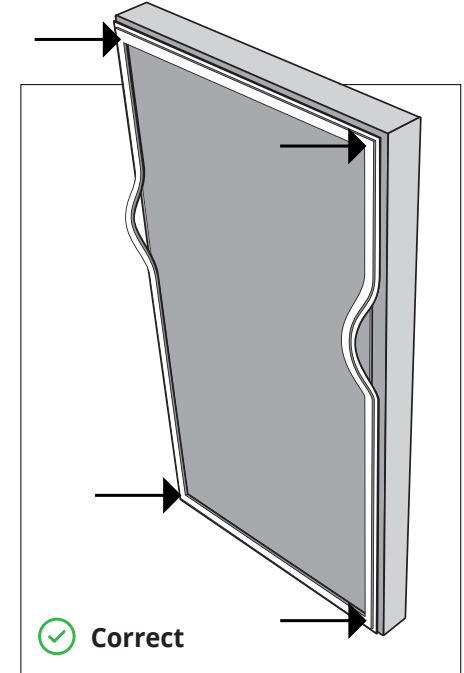

- Is the seal properly pushed into the tracking all the way around?
- Have all creases or cracks been removed with a blow dryer or heat gun?
- Is the door, drawer or lid not crooked or twisted?
- Does the cabinet face contain a counter magnet that repels the seal?
- Does the seal wrench on the hinge side? If so, put the door without hinges against the cabinet and re-install the hinges.

## Maintenance



The life span of a fridge seal will be extended when properly cleaned on a daily basis. Fats & Food spills cause the material that seals are made of to dry out and get brittle which then cause it to rip easily. Cleaning daily can prevent this from happening. Be mindful that an intact and clean seal is also important for general kitchen hygiene and food safety.

### Advice

A split, worn or broken fridge seal has a significant impact on the cooling capacity and energy consumption of refrigeration equipment. Without a proper seal, the refrigerator or freezer “leaks” cold air causing the cooling compressor to run more frequently or even continuously in order to keep the cabinet contents at the set temperature. Maintenance of fridge seals is important for food safety; it avoids maintenance cost and reduces the energy consumption up to 25%.

### General

Use a soft dry cloth with a professional fridge seal cleaner or a heavily diluted water-based cleaning agent for maintenance. Be mindful that aggressive cleaning agents, such as all-purpose cleaners, sanitisers, oven cleaners and aggressive degreasers cause irreparable damage when used on fridge seals.

## Cleaning

- 1 Remove any visible forms of contamination such as crumbs from in-between the folds of the seal. Use a brush or a clean dry cloth. Don't use any sharp objects to get in-between the folds because this can cause irreparable damage to the seal.
- 2 Apply the (diluted) cleaner on the seal with the spray bottle or a cloth.
- 3 Let it sit for 30 seconds.
- 4 Wipe dry with a clean dry cloth, also between the folds. Repeat treatment until the seal is entirely clean.

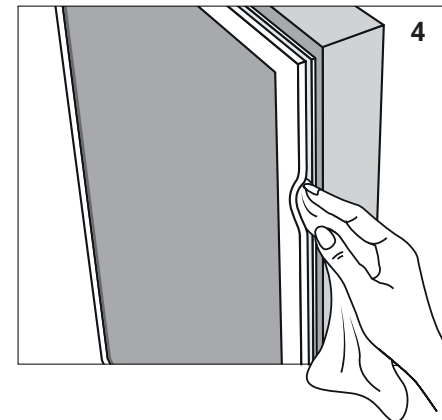
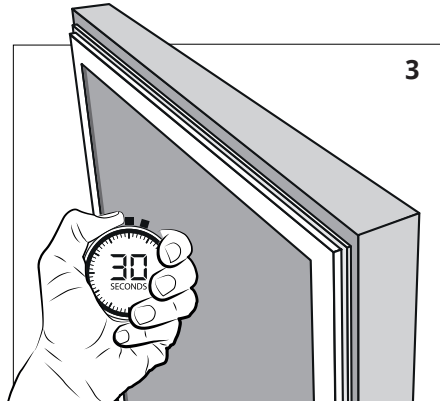
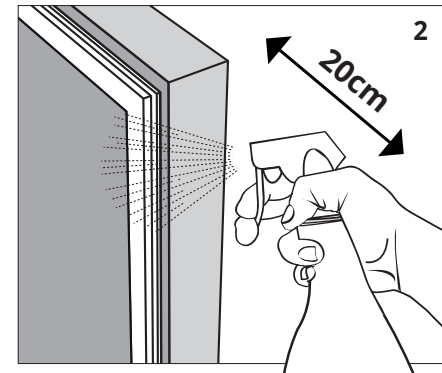
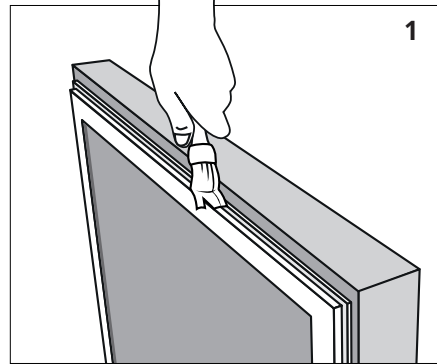



1

Dart profiles with magnet  
Available as frame or profile length.

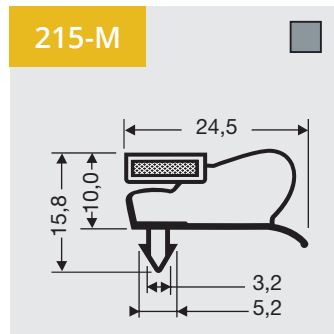
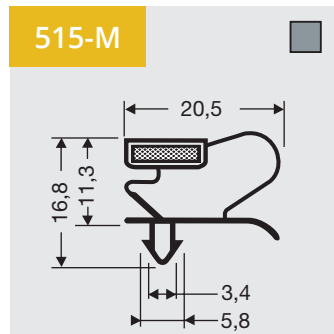
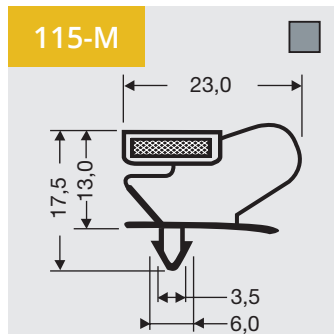
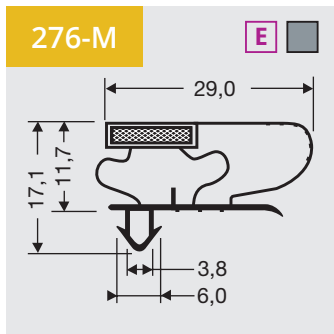
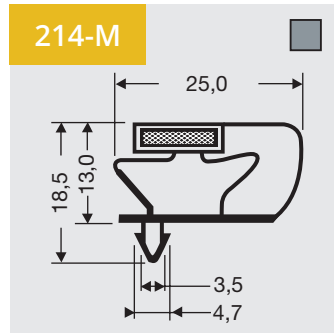
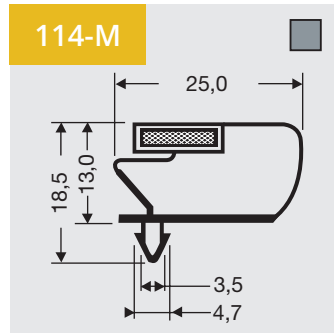
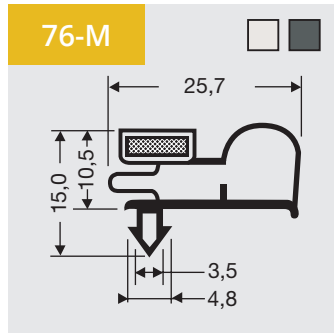
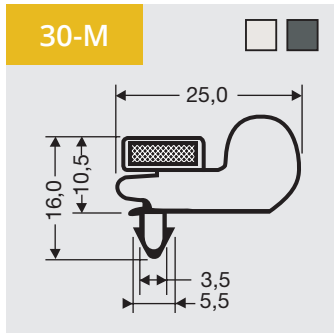
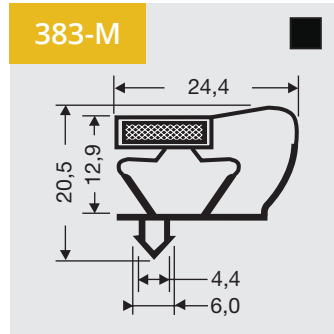
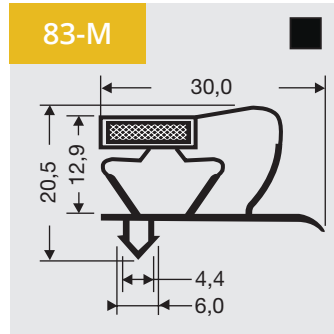
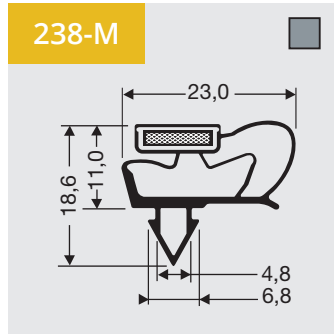
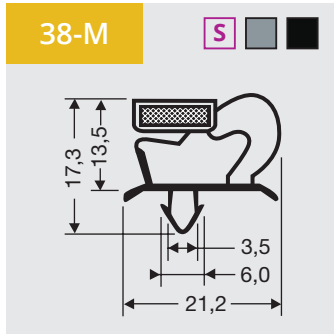

# 1

**Dart profiles with magnet**  
Available as frame or profile length.

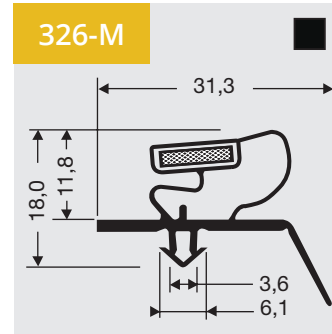
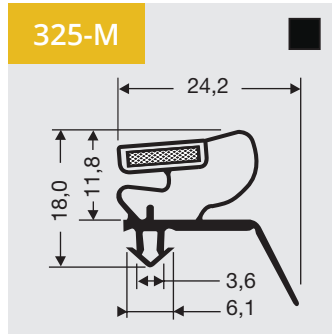
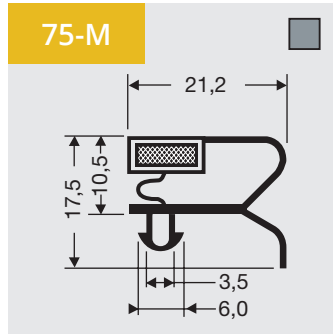
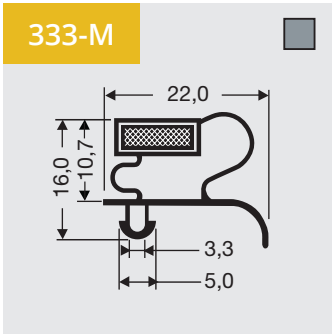
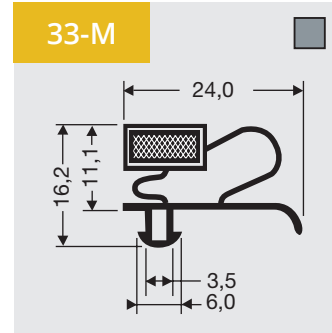
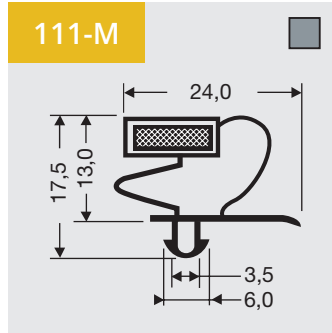
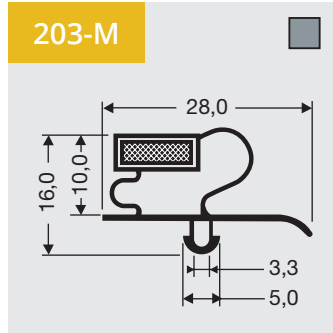
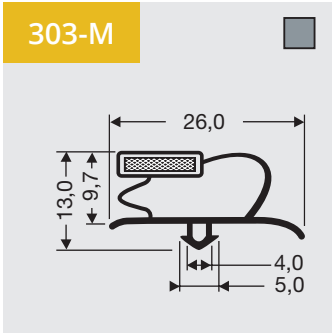
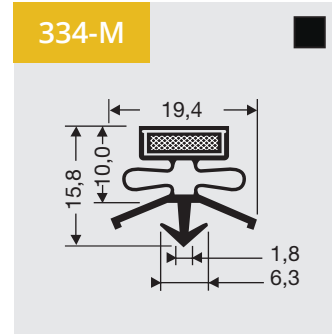
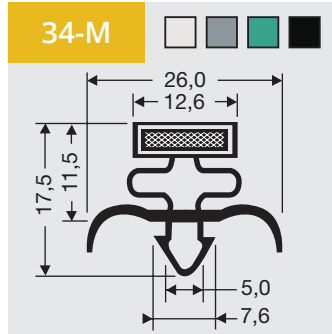
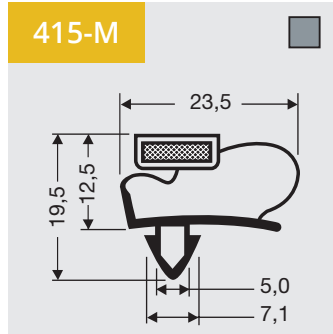
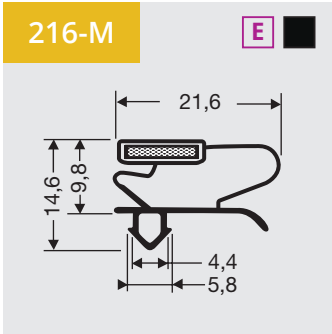





1

Dart profiles with magnet  
Available as frame or profile length.

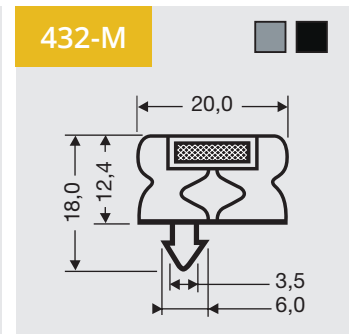
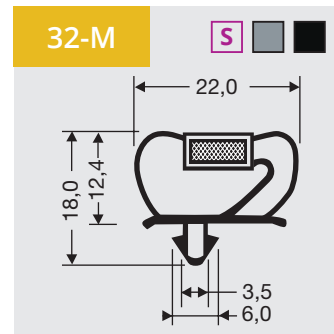
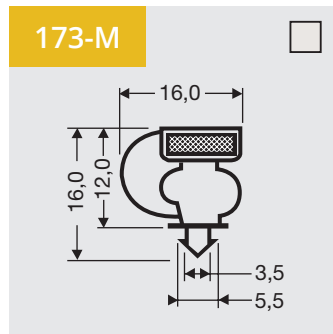
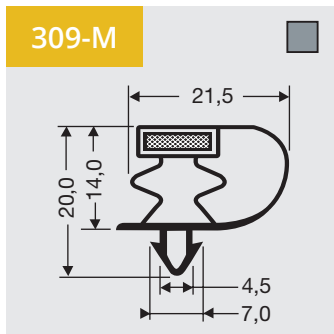
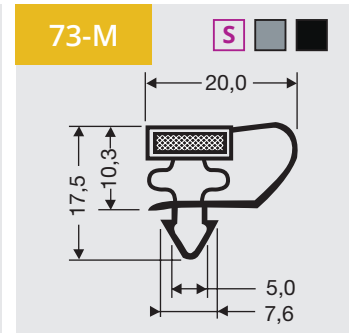
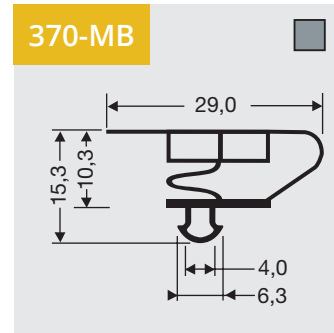
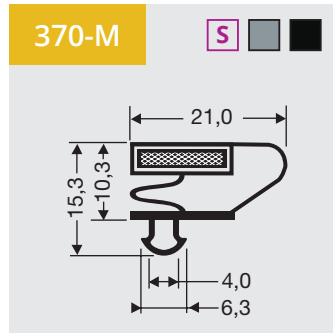
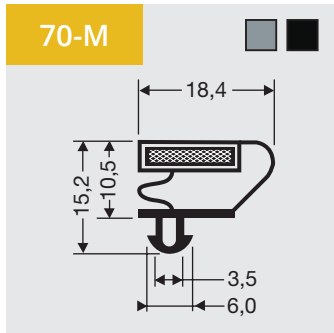
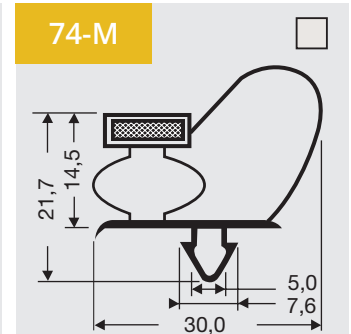
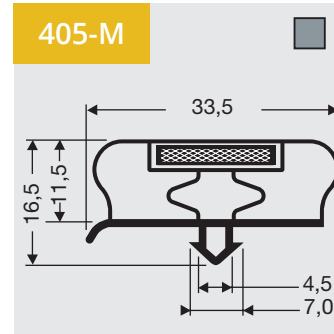
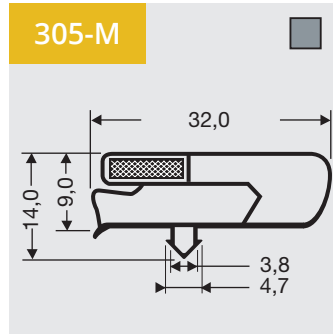
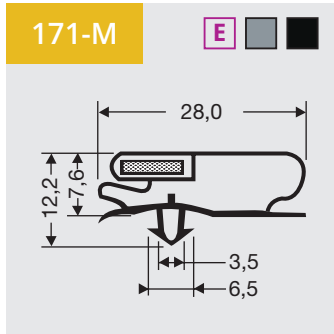

Copyright 2022 DSU BV  
September 2022

# 1

**Dart profiles with magnet**  
Available as frame or profile length.

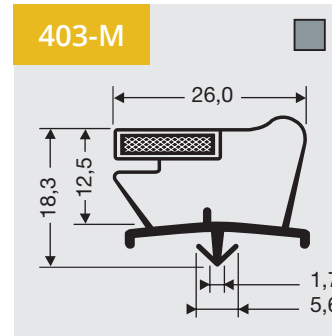
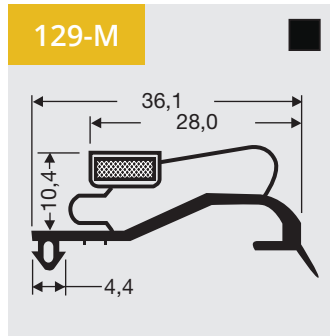
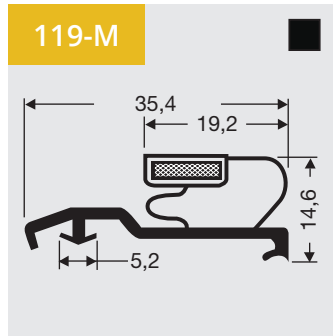
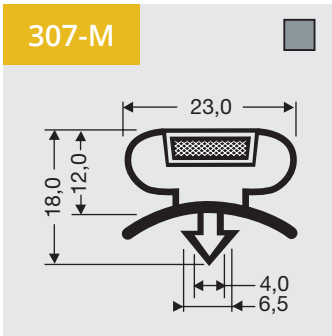
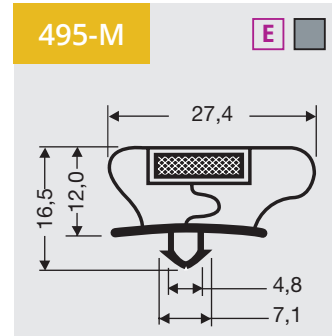
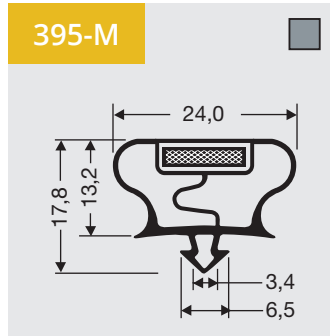
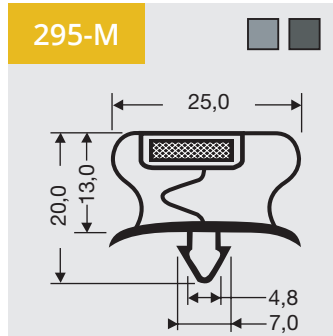
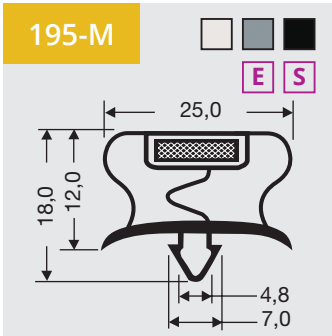
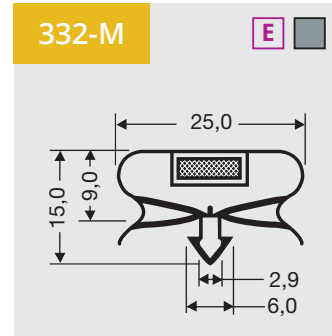
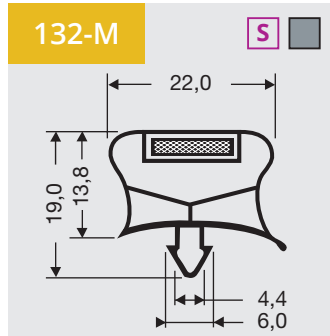
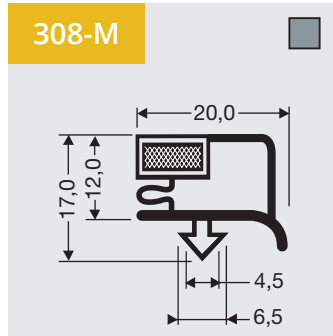
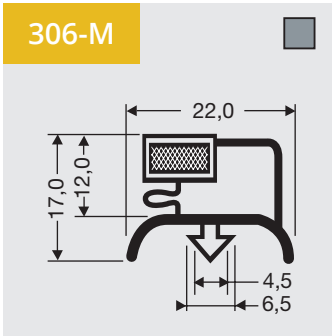



1

Dart profiles with magnet  
Available as frame or profile length.

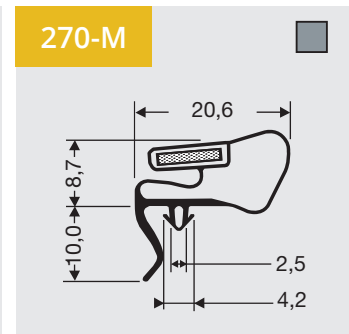
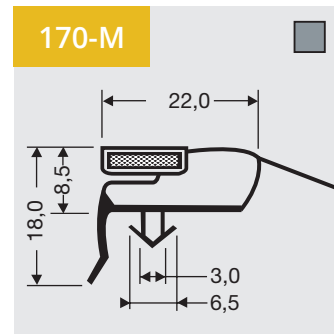
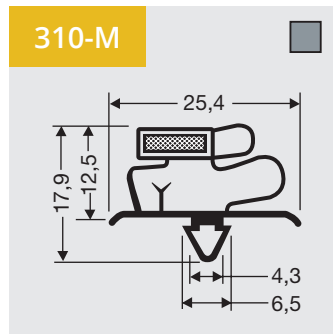
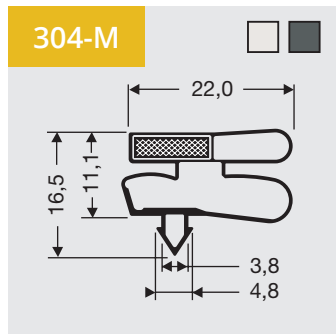
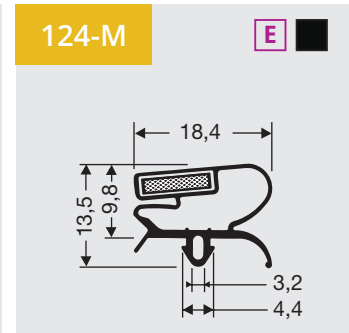
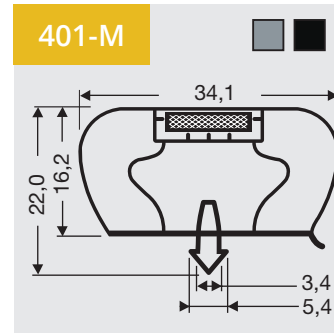
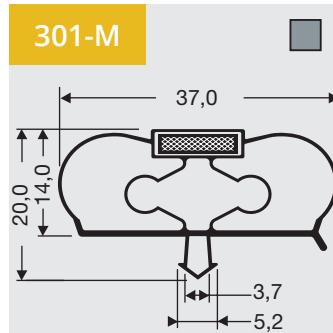
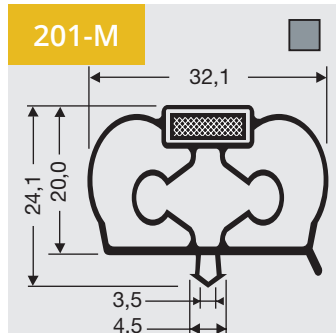
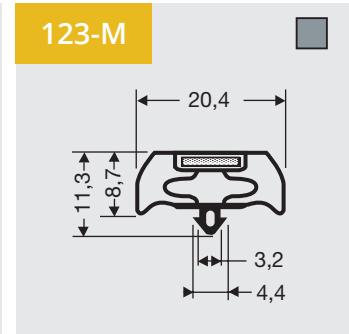
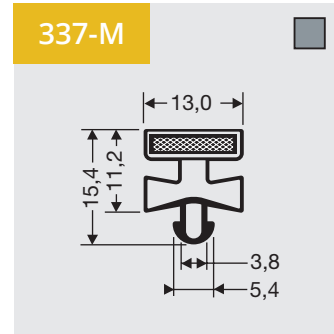
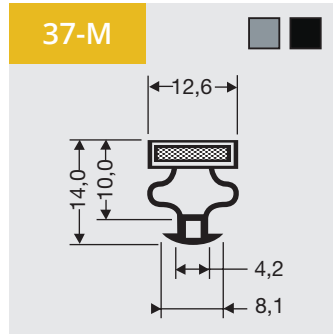
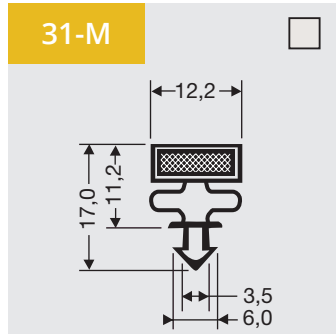



1

### Dart profiles with magnet

Available as frame or profile length.

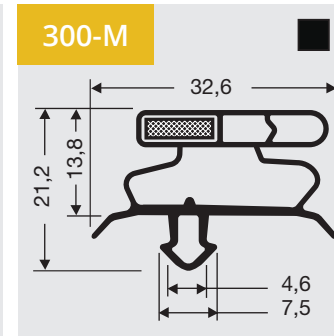
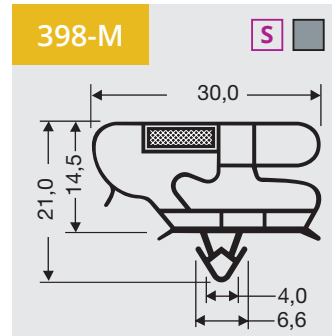
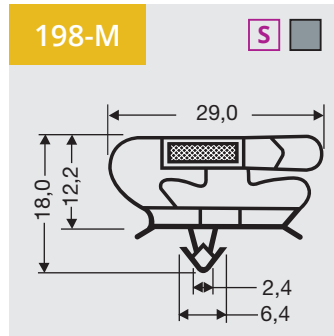
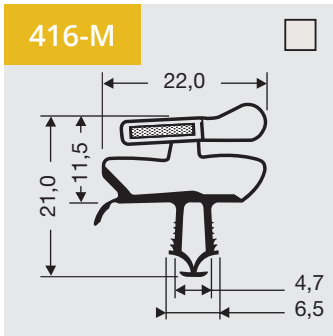
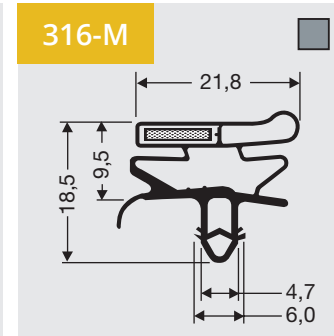
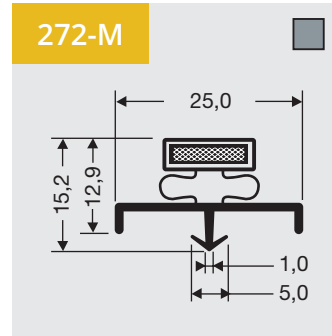
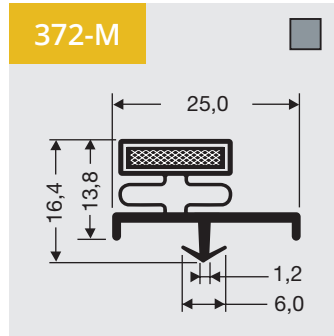
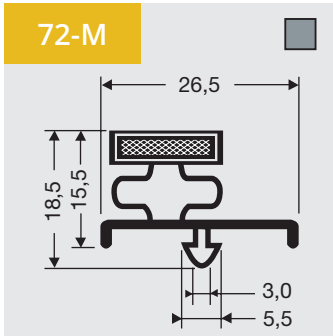
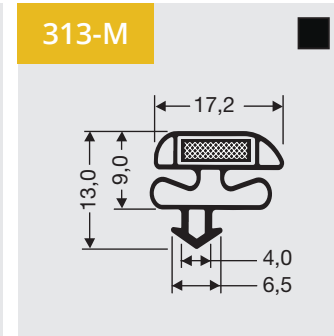
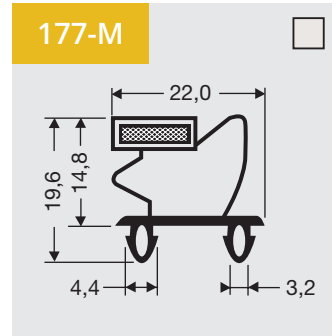
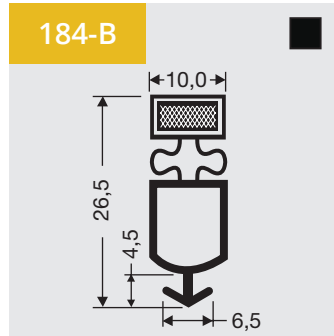
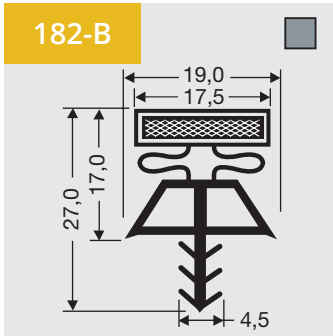



## 2

Dart profiles, large  
dart with magnet  
Available as frame or  
profile length.

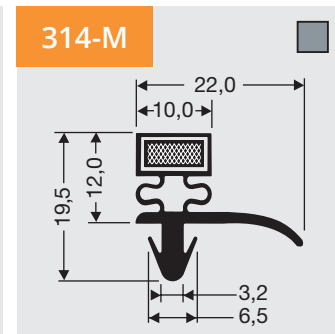
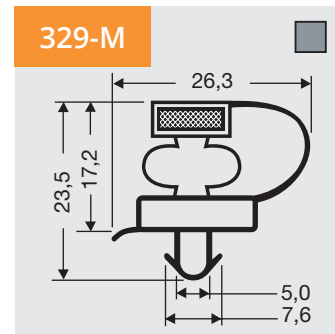
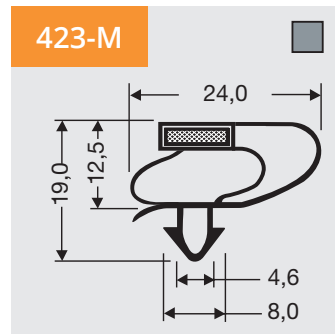
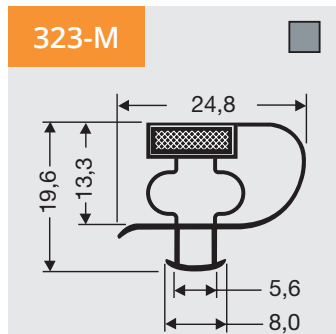
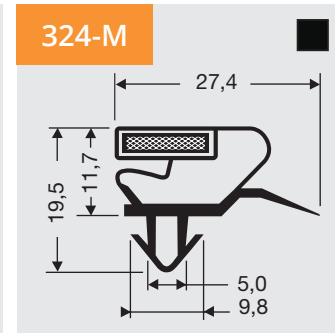
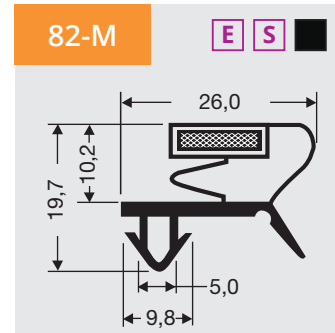
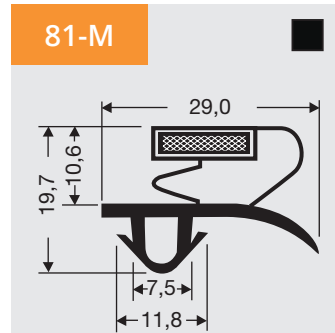
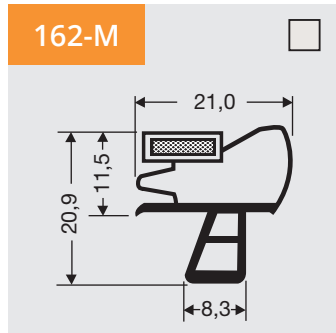
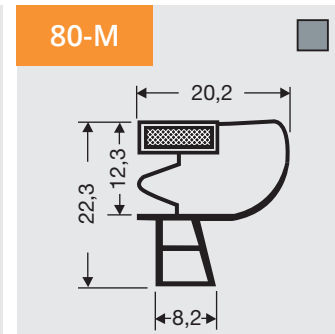
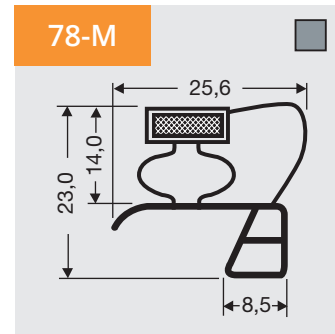
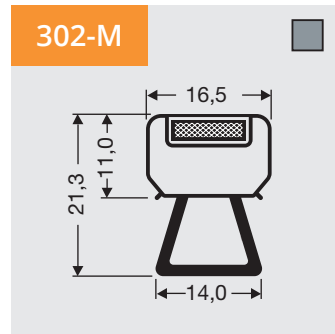
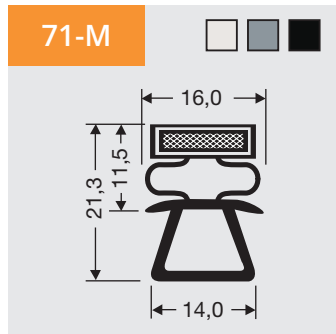

Copyright 2022 DSU BV  
September 2022



**Dart profiles, large  
dart with magnet**  
Available as frame or  
profile length.

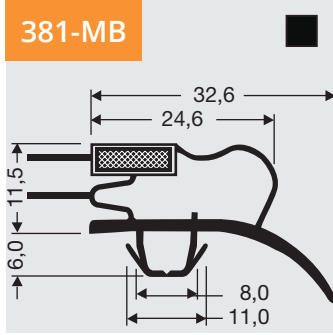
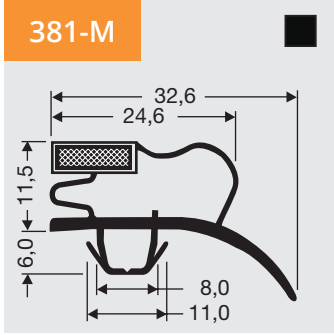
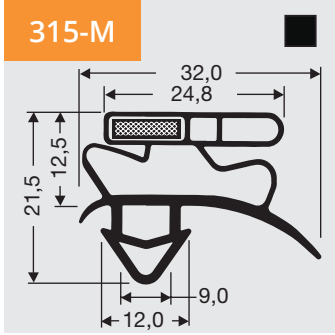
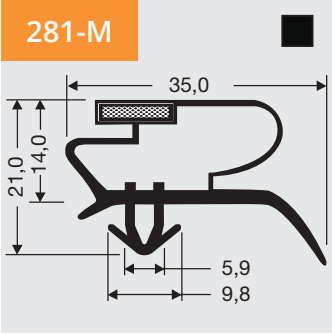
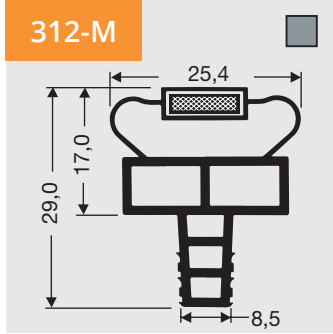
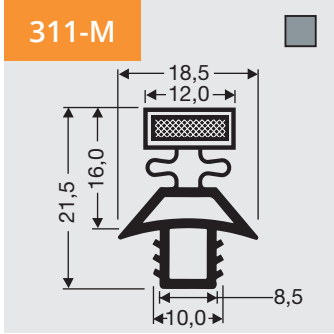
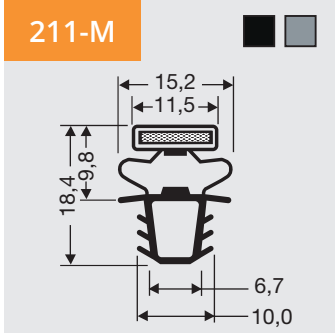
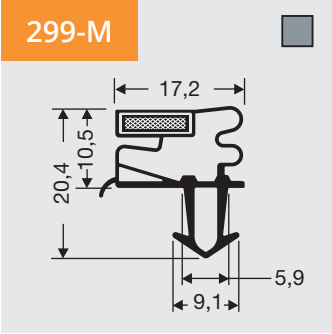
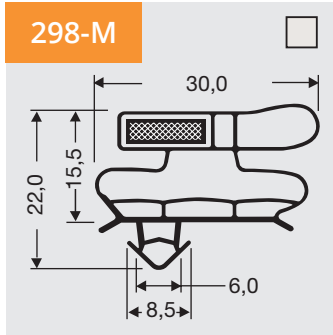
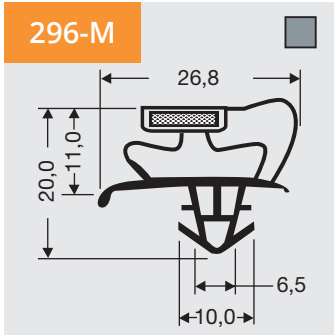
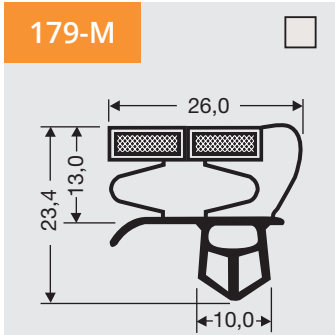
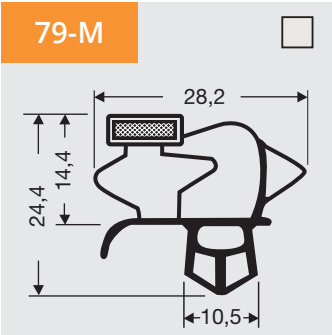



## 2

### Dart profiles, large dart with magnet

Available as frame or profile length.

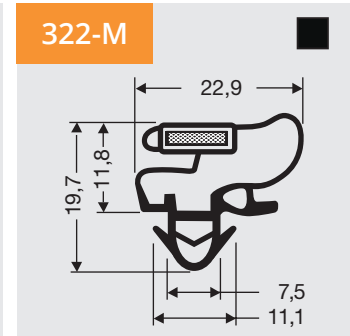
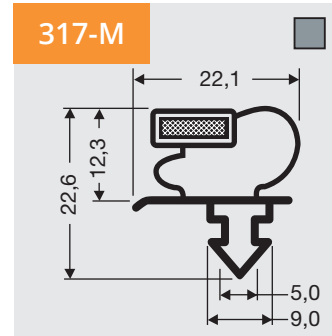
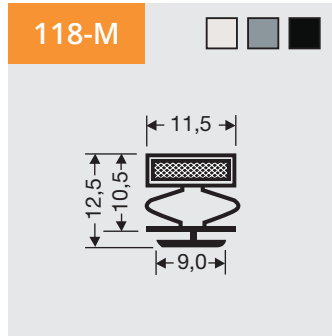
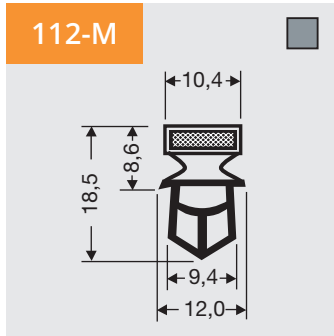

Visit our website for all profiles and quotations

[www.dsu-nl.com](http://www.dsu-nl.com)



### *How to take the dart-to-dart measurements (C size)*

Remove the seal from the track to take the dart-to-dart measurements.

Measure from the inside edge of the slot on one side to the outside of the slot on the other side.



### 3

Dart profiles  
without magnet  
Available as frame or  
profile length.

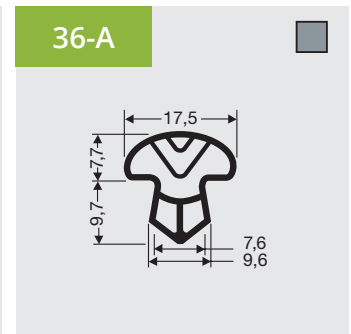
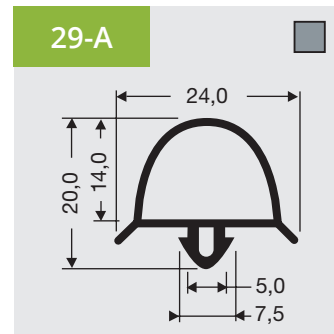
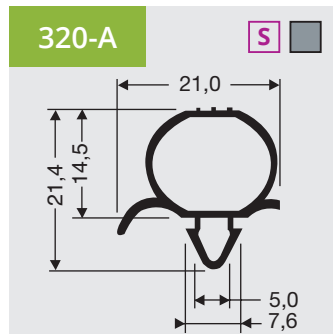
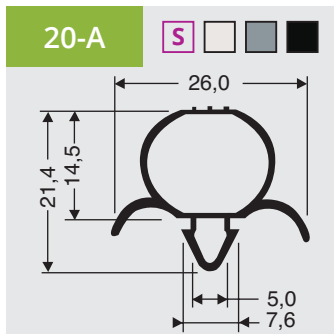
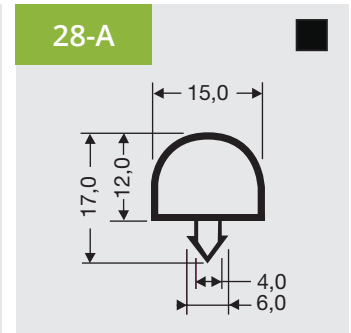
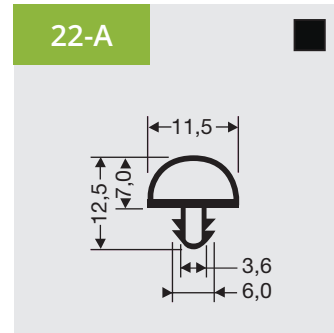
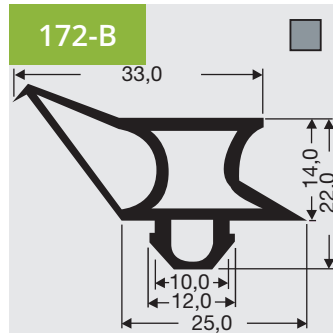
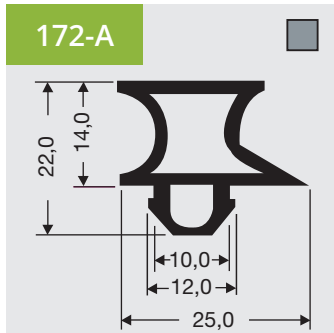
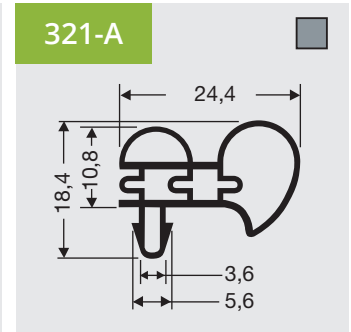
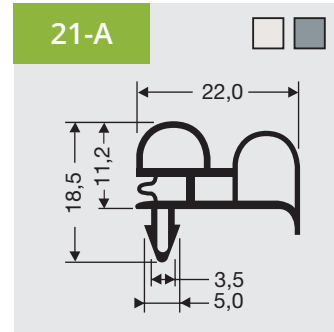
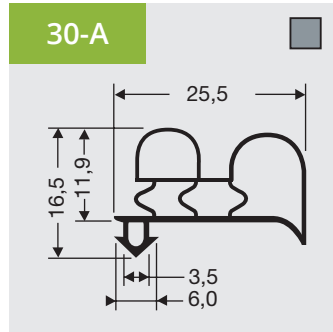
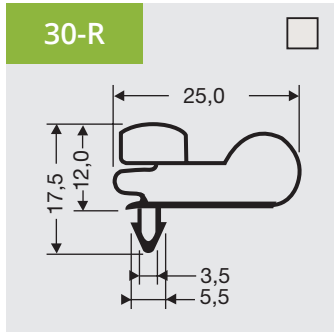



### 3

**Dart profiles  
without magnet**  
Available as frame or  
profile length.

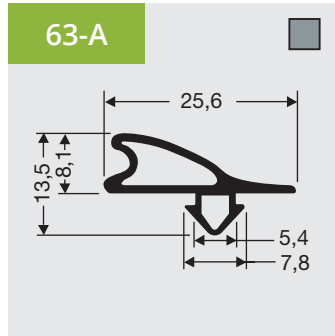
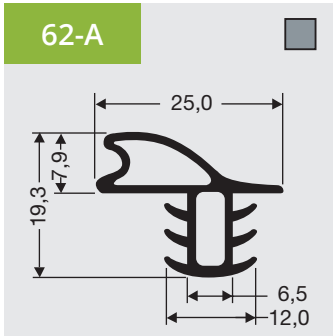
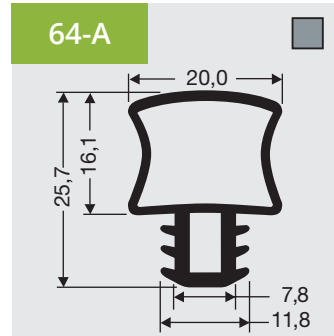
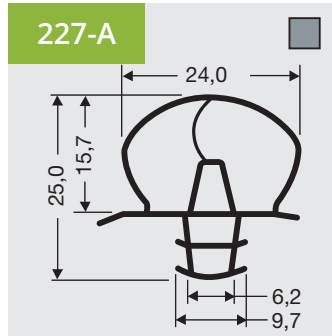
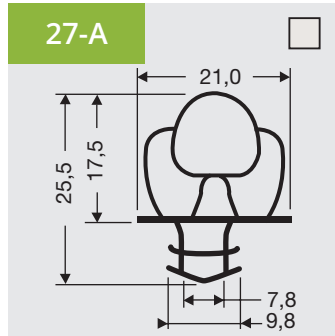
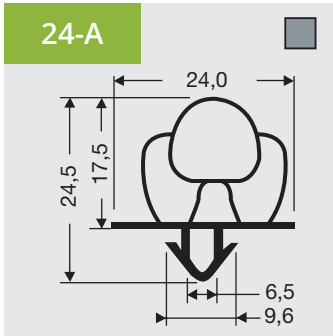

Visit our website for all  
profiles and quotations

[www.dsu-nl.com](http://www.dsu-nl.com)





# 4

Lip profiles with magnet  
Available as frame or profile length.

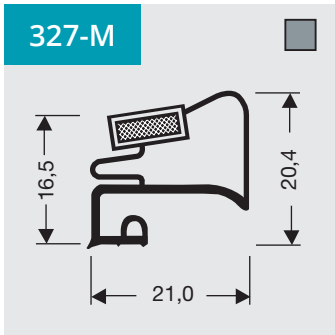
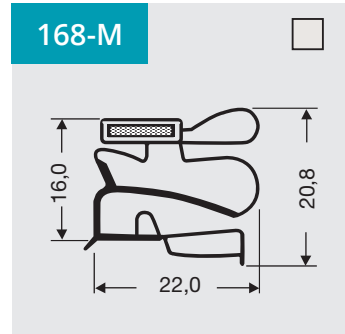
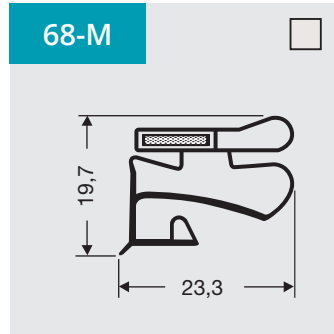
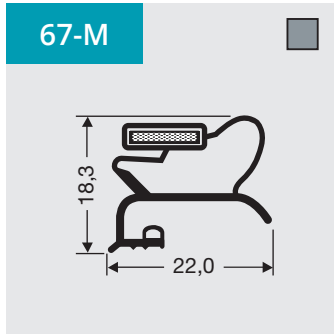
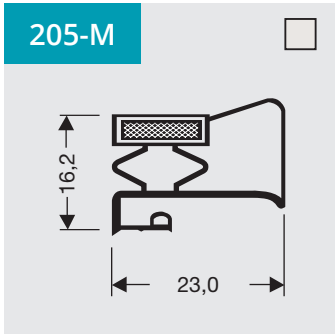
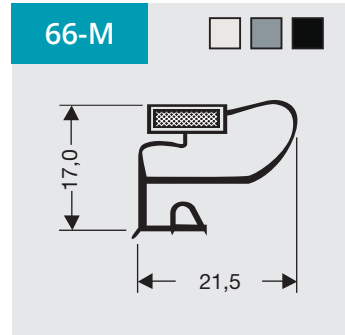
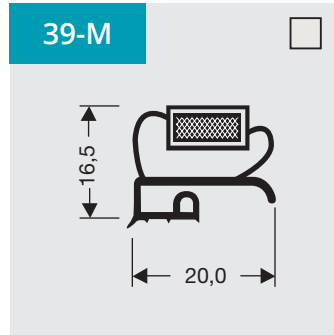
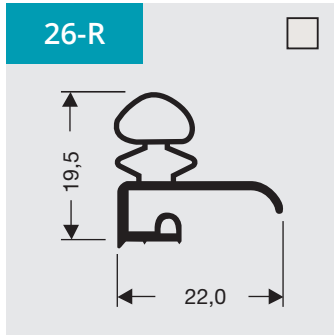
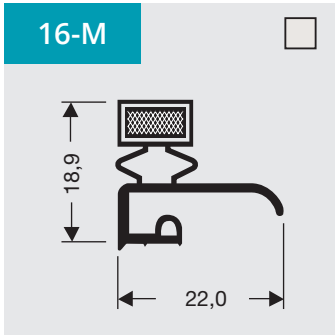

Visit our website for all profiles and quotations

[www.dsu-nl.com](http://www.dsu-nl.com)



*How to take the outside-to-outside measurements (A size)*

We advise to measure the seal width and height while it is still fitted in the door or drawer.

The outside-to-outside measurements (A size) can be applied for all types of fridge seals.



# 5

## Flap profiles with magnet

Available as frame or profile length.

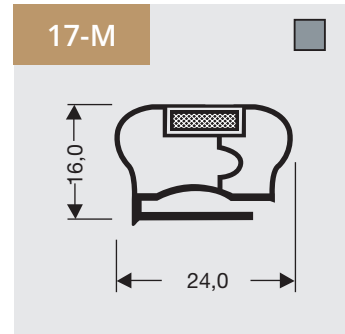
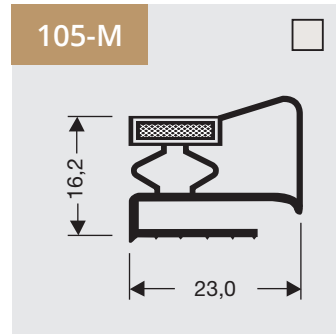
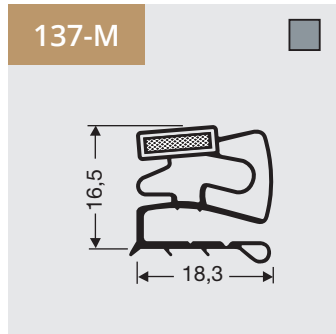
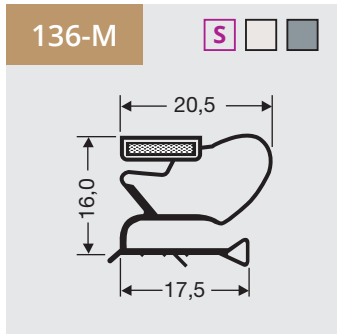
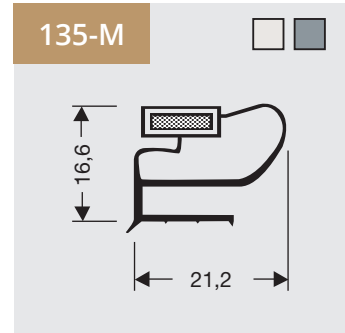
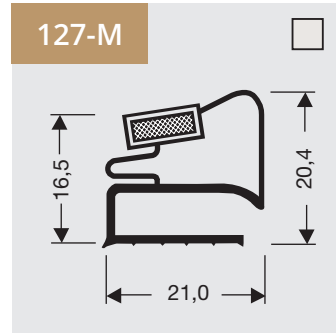
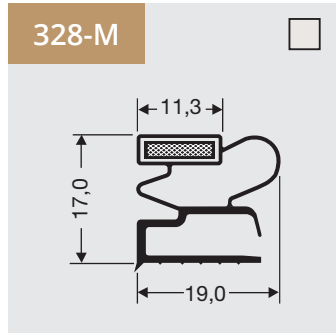
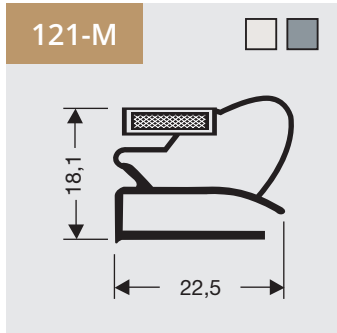
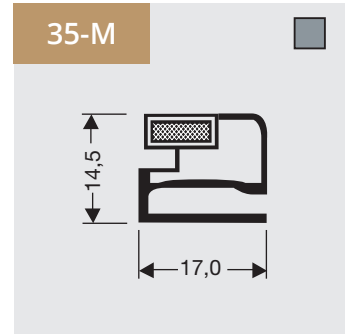
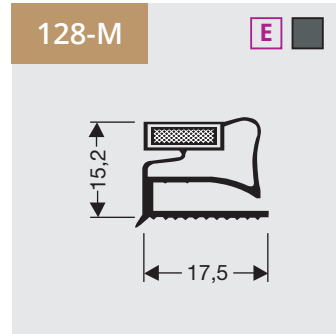
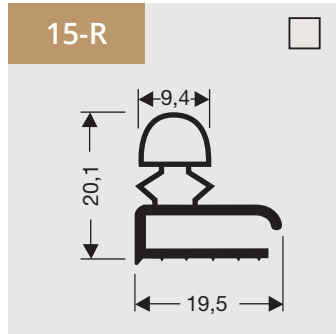
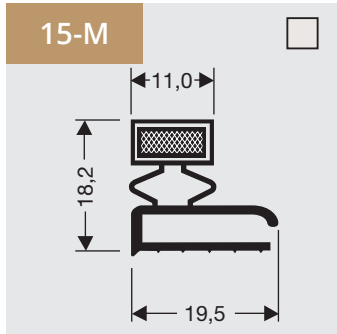



# 5

**Flap profiles with magnet**  
Available as frame or profile length.

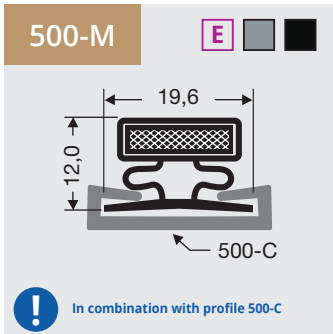
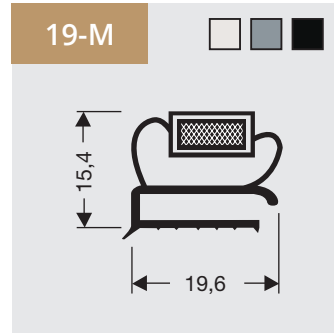
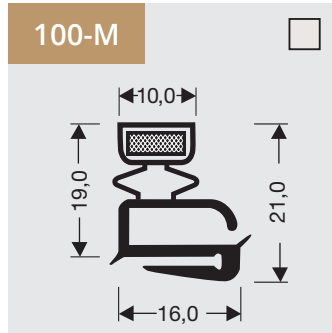
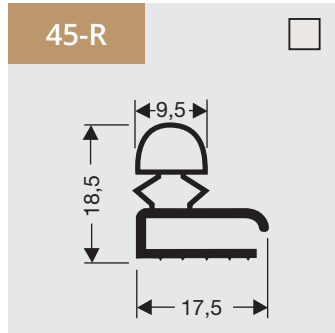
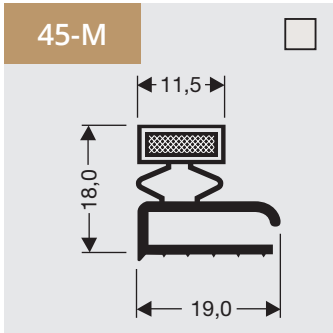
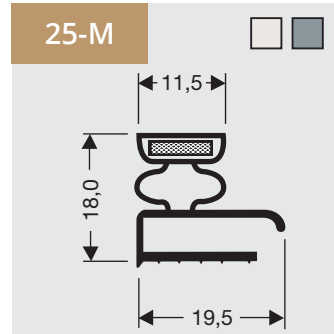
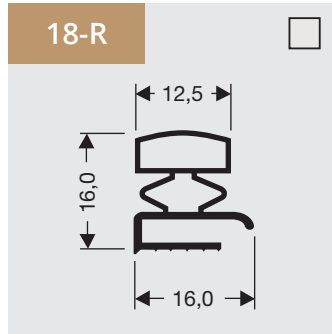
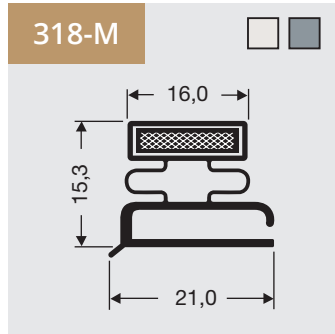
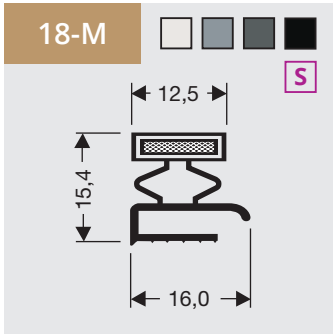

Visit our website for all profiles and quotations

[www.dsu-nl.com](http://www.dsu-nl.com)



# 6

## Compression profiles without magnet

Available as frame or profile length.

<b>4-A</b>	<b>6-A</b>	<b>7-A</b>	<b>9-A</b>
<b>10-A</b>	<b>210-A</b>	<b>122-A</b>	<b>5-A</b>
<b>102-A</b>	<b>104-A</b>	<b>158-A</b>	<b>169-A</b>



# 6

**Compression profiles  
without magnet**  
Available as frame or  
profile length.

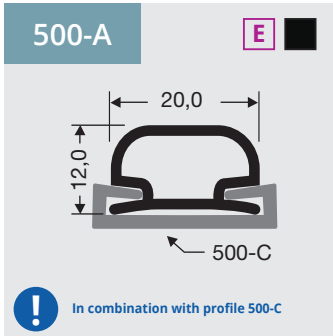
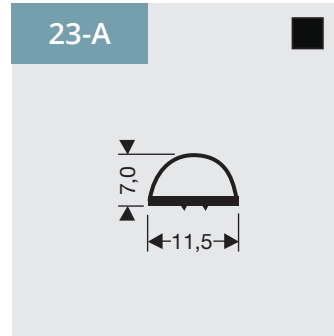
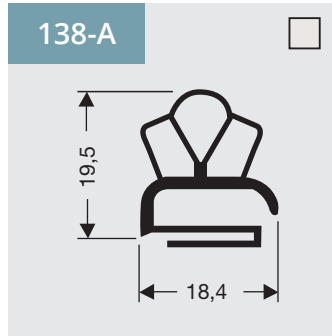
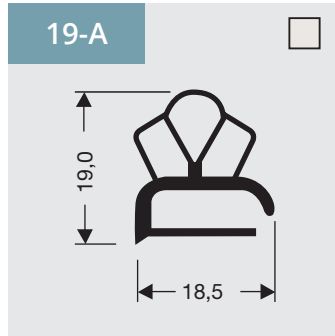
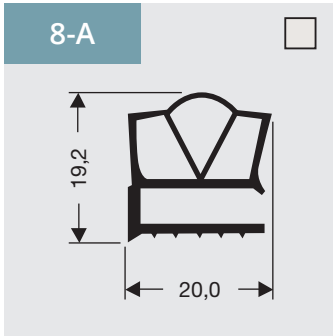

Visit our website for all  
profiles and quotations

[www.dsu-nl.com](http://www.dsu-nl.com)

**Profiles which can be counter-welded**

**!** *Attention: Check carefully if you are dealing with a counter (welded) profile. These are very rarely used.*

**Profiles which can be counter-welded**

With counter welding, the profile is mirrored horizontally. The flap profiles are open outwards in the counter-welded variant instead of inwards which is standard. The result for dart type profiles is that the magnet which is positioned on the outside of the seal as a standard is then positioned on the inside.

These profiles can be produced counter-welded as a standard. On request, we can investigate for the other profiles in this catalogue to be offered as counter-welded.

**Example**

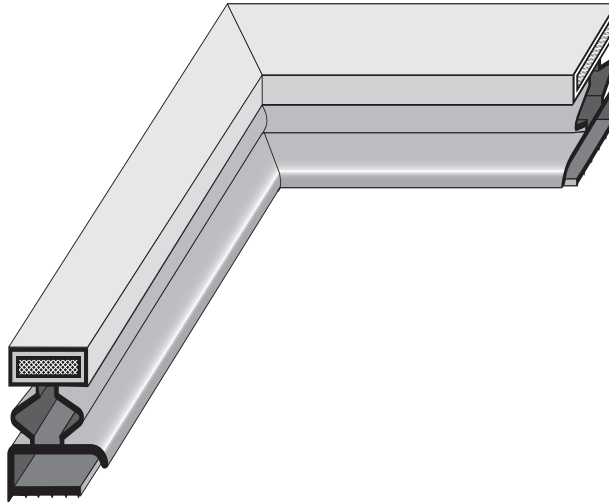

**Normal 18-M**  
Flap open to the inside

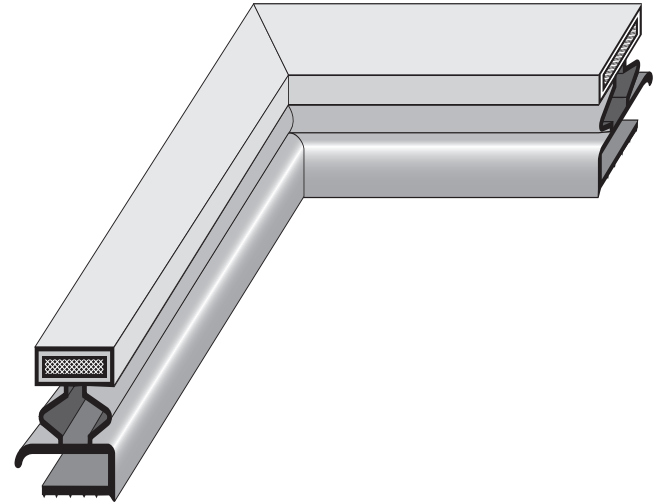

**Contra 18-MC**  
Flap open to the outside

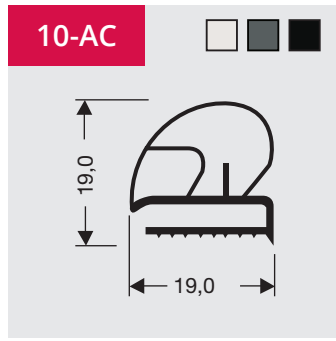
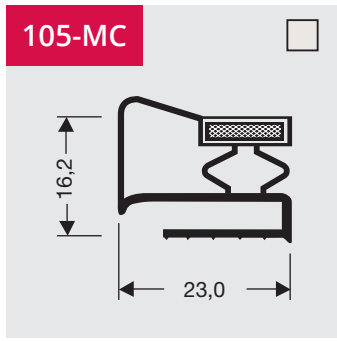
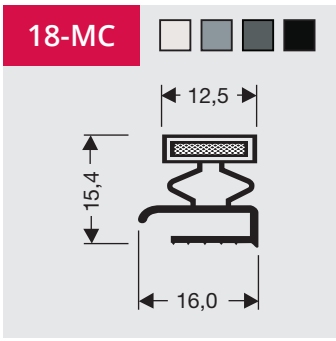

Visit our website for all profiles and quotations

[www.dsu-nl.com](http://www.dsu-nl.com)



# 7

Profiles which can be counter-welded





8

### Profiles made of special compounds

Available as frame or profile length.

### Soft PVC profiles (-MS)

Profiles with the extension -MS are made of a special blend of materials. Seals made of soft PVC have several advantages compared to regular PVC, of which the most important:

- Less sensitive to the effects of fats.
- Temperature range from -30 °C to 60 °C

For these reasons we advise this type of seals for the use in Shock Freezers, Blast Chillers, Freezer room doors and for sealing doors and drawers of refrigeration equipment with a high usage intensity.

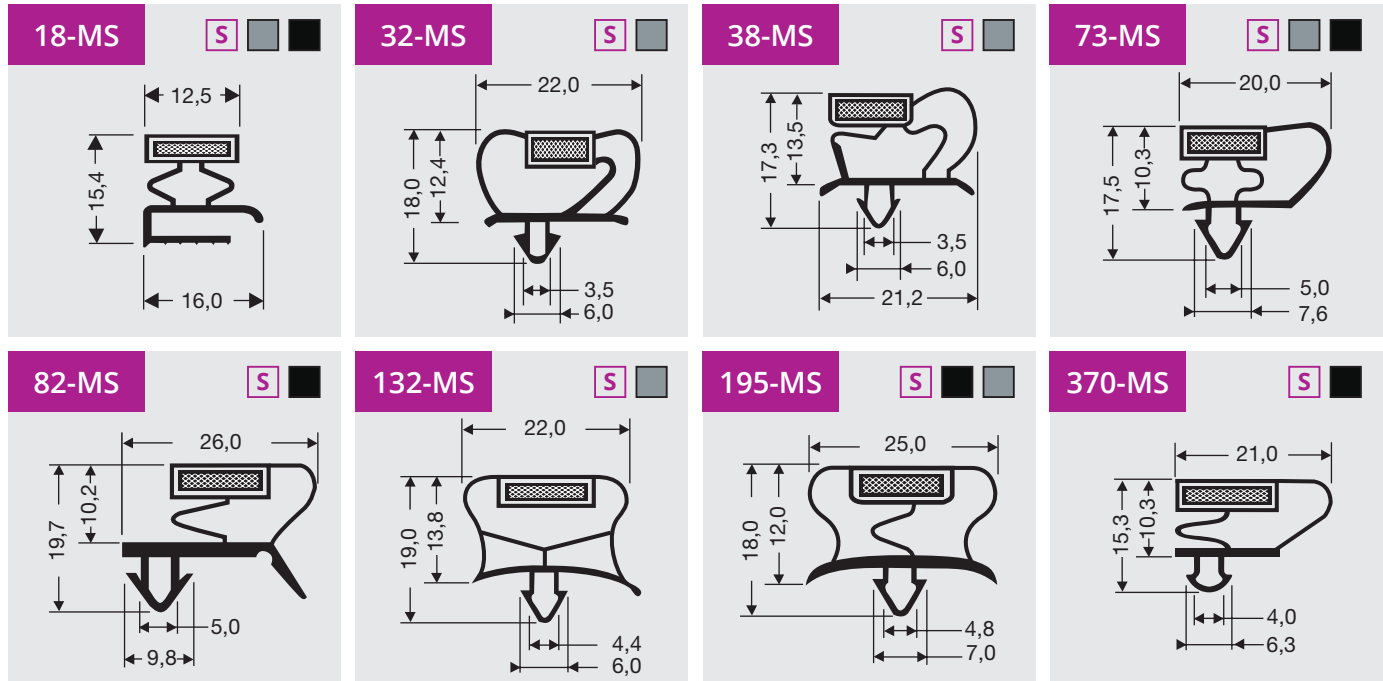

**Profiles made of special compounds**

Available as frame or profile length.

**Profiles standard in soft PVC**

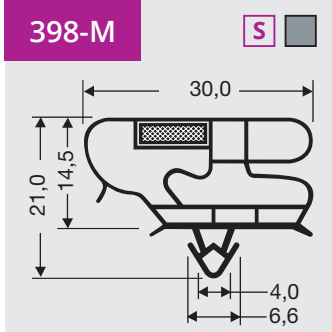
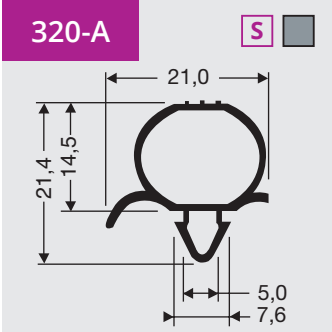
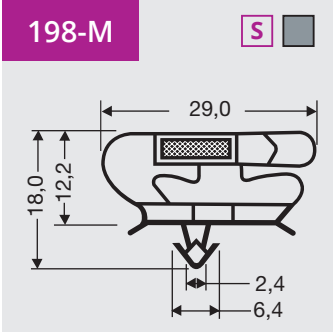
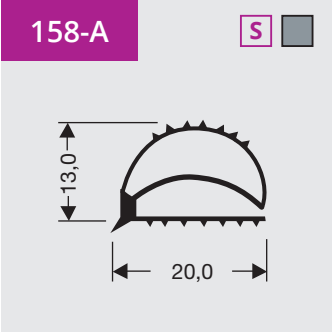
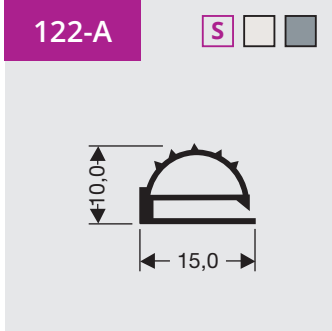
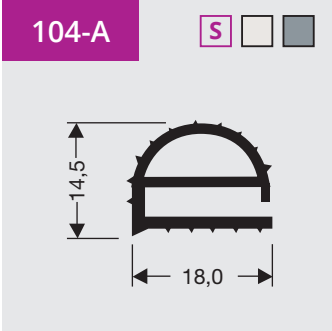
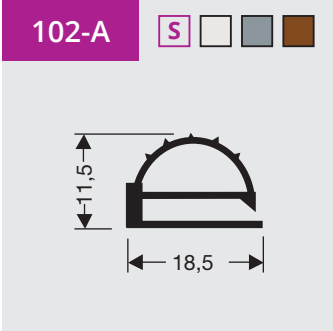
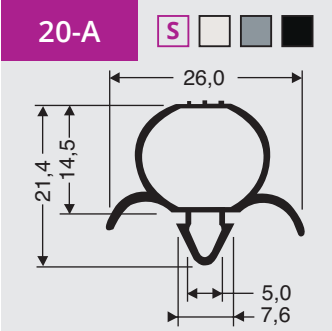



8

### Profiles made of special compounds

Available as frame or profile length.

#### TPE profile (-ME)

Profiles with the extension -ME are made of Thermoplastic Elastomers (TPE). Seals made of this high-grade thermoplastic rubber compound have several advantages compared to regular PVC and soft PVC, of which the most important:

- Less sensitive to the effects of fats
- Less sensitive to (aggressive) cleaning agents including disinfectants
- Temperature range from -40 °C to 130 °C

For these reasons we advise to use TPE seals in doors and drawers with high usage intensity, Ultra Low Temperature Freezers, shockfreezers, blast chillers, heated cabinets and climate cabinets.

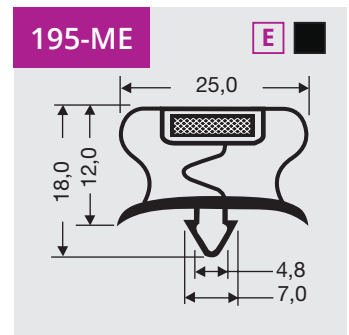
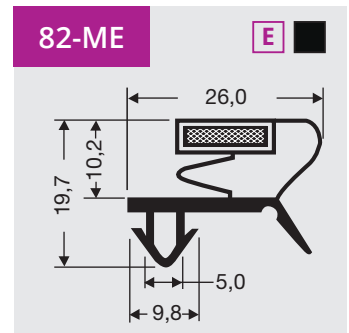

**Profiles made of special compounds**

Available as frame or profile length.

**Profiles standard in TPE**

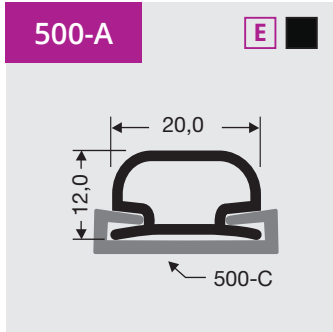
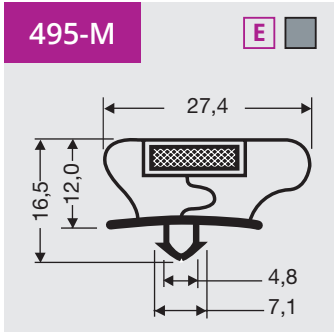
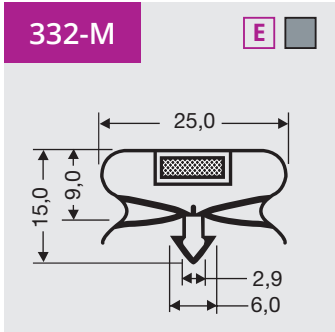
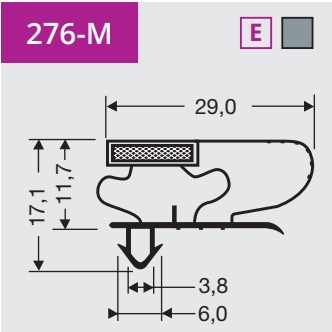
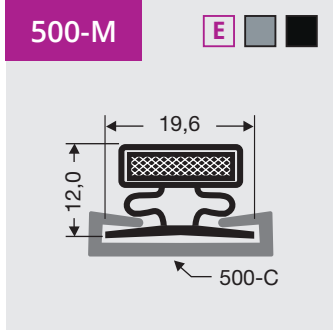
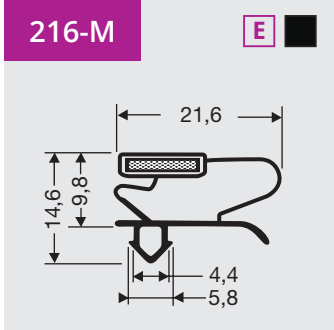
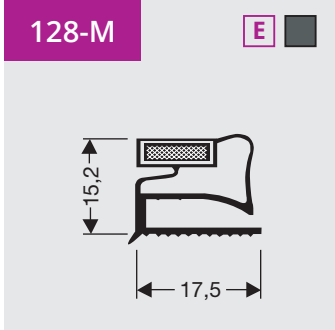
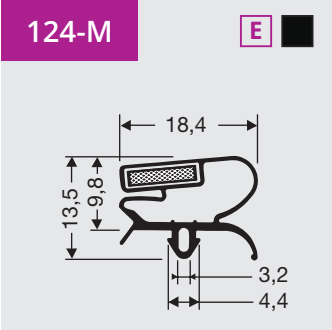

# 9

**Silicone profiles-**  
Available on a coil or  
by the meter.

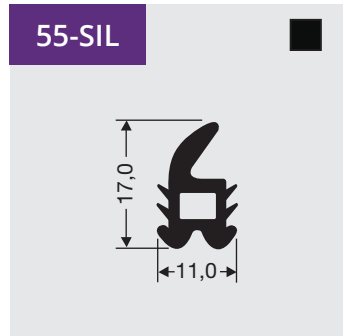
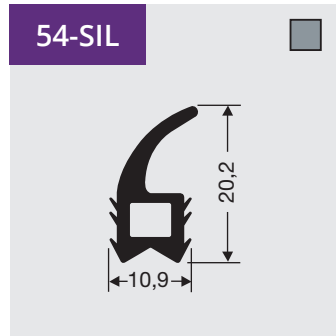
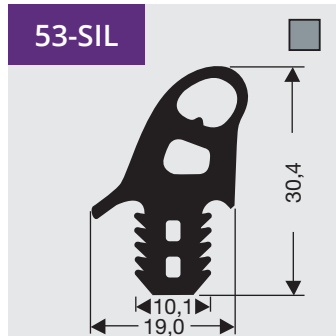
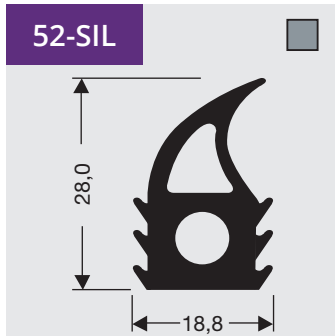
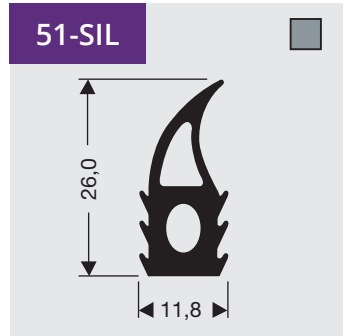
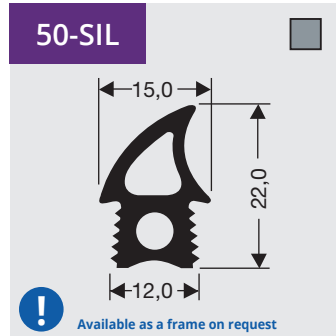
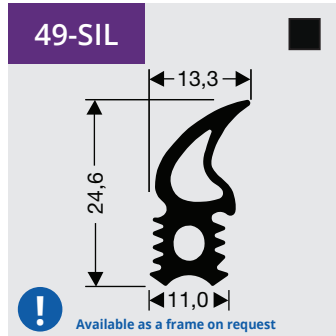
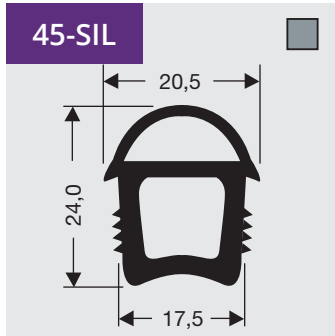
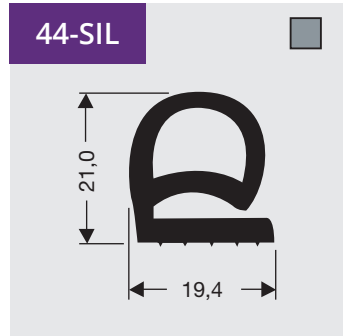
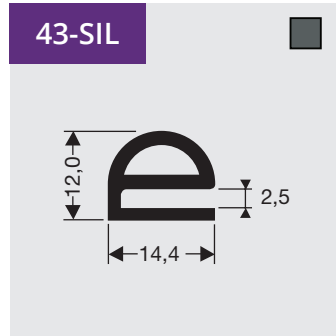
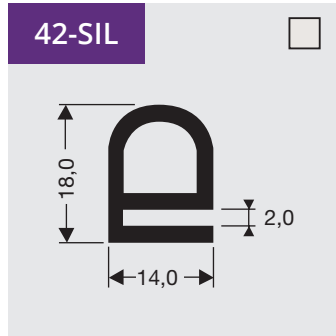
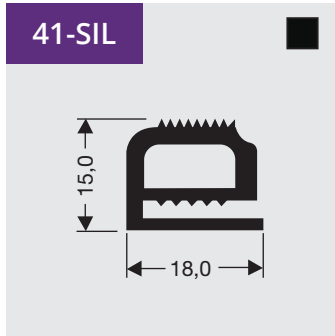

# 9

**Silicone profiles-**  
Available on a coil or  
by the meter.

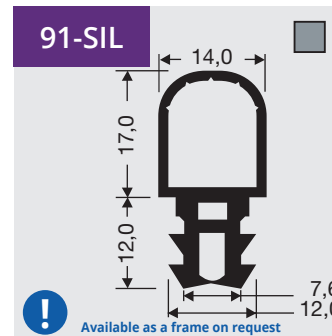
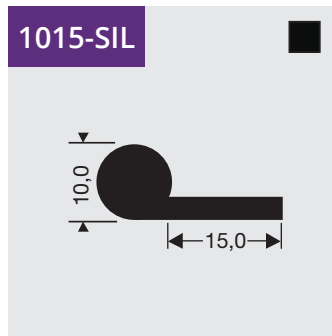
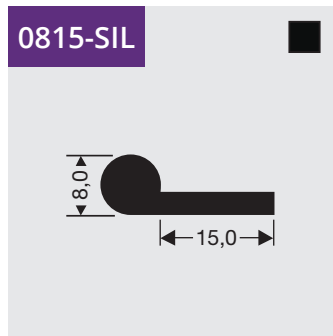
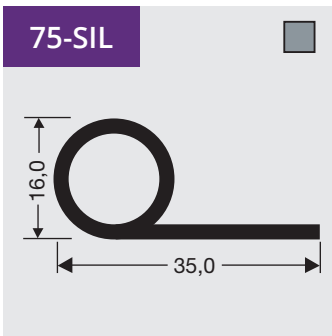
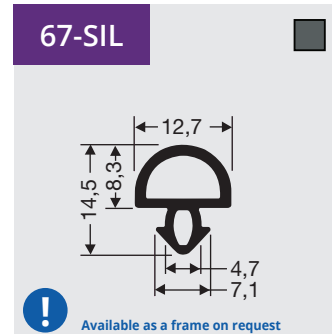
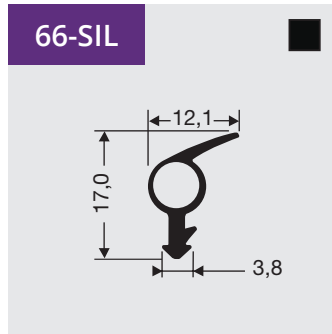
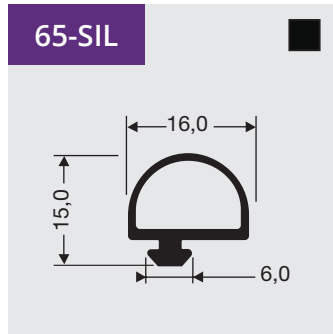
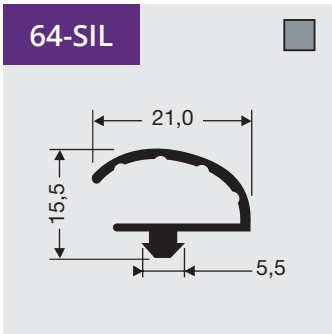
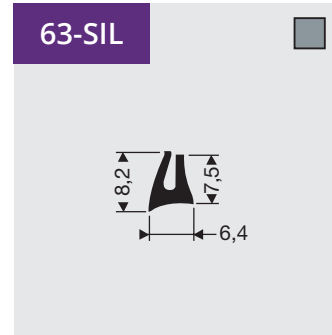
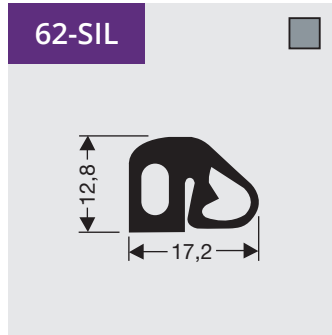
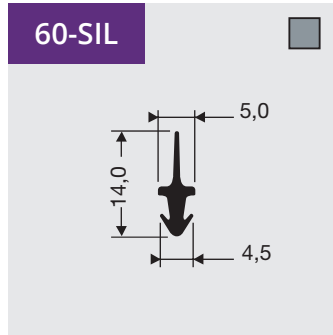
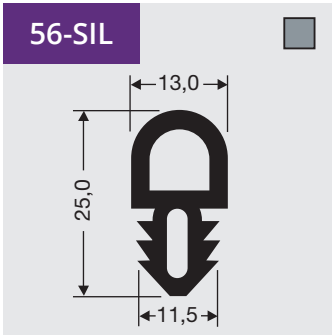



# 10

Rubber profiles  
Available on a coil or  
by the meter.

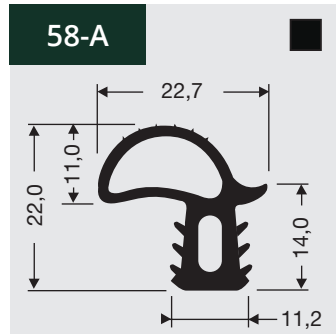
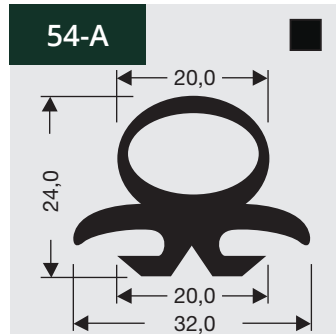
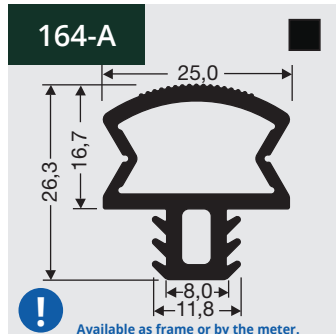
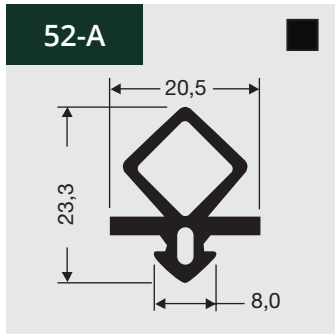
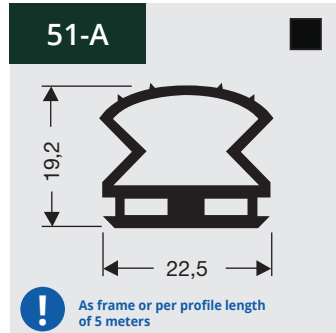
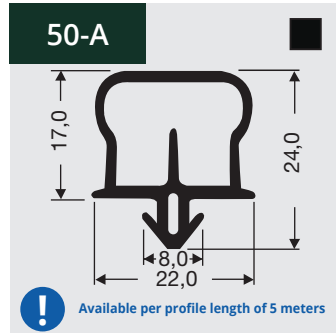
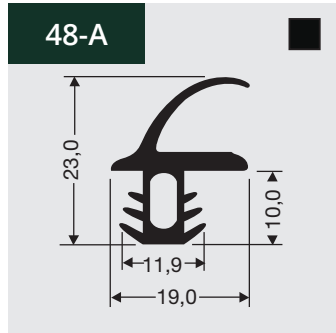
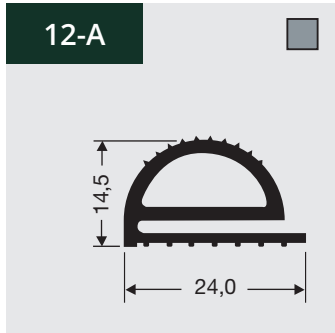
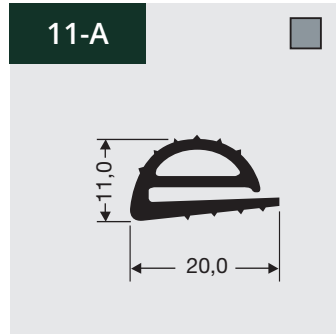
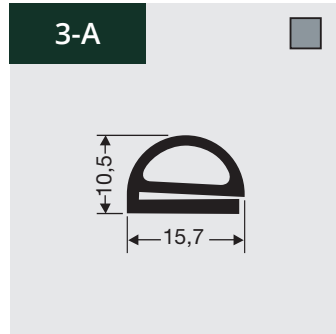
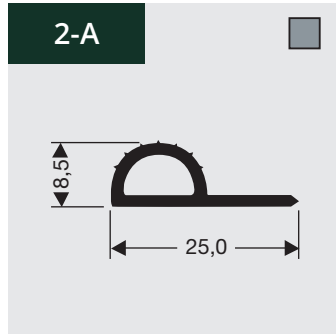
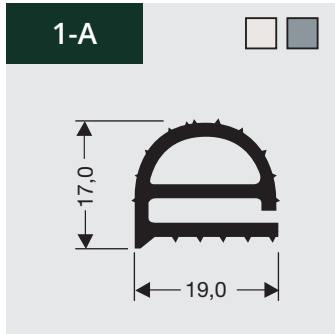

**Rubber profiles**  
Available on a coil or  
by the meter.

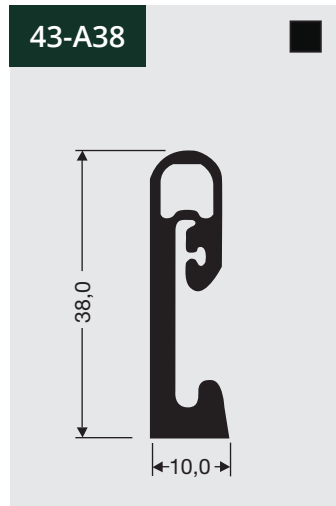
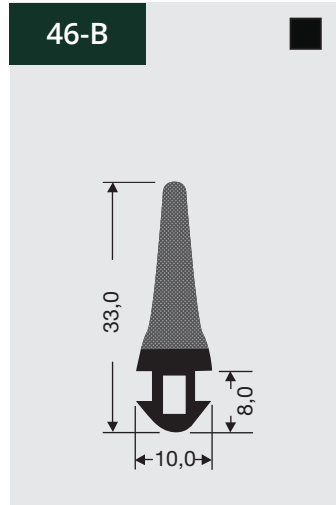
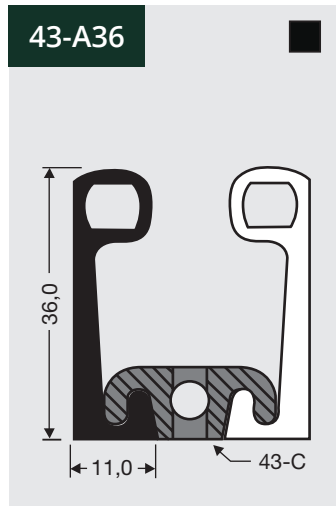
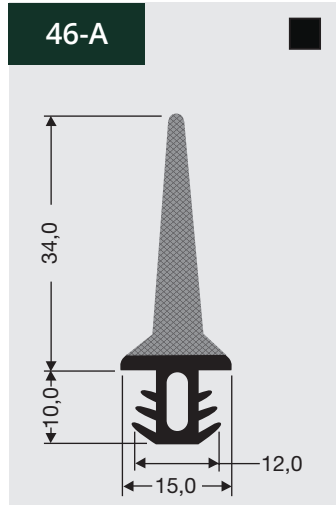
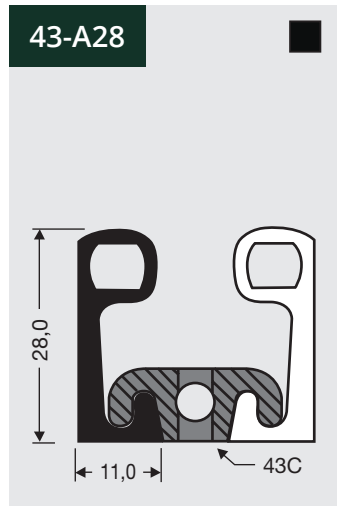
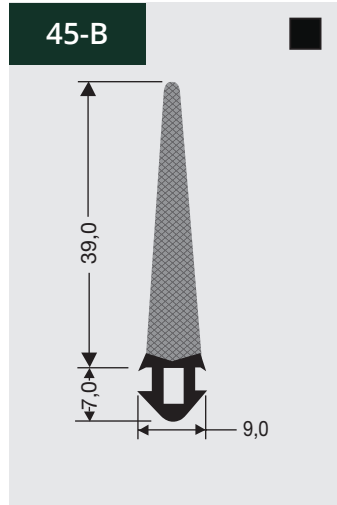
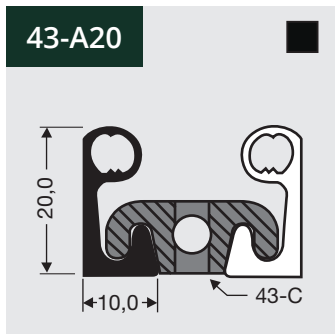
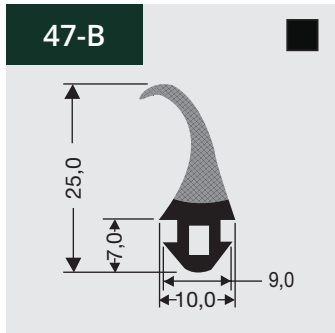
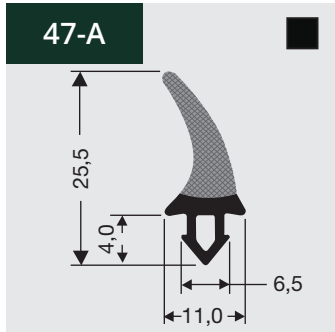





# 10

Rubber profiles  
Available on a coil or  
by the meter.

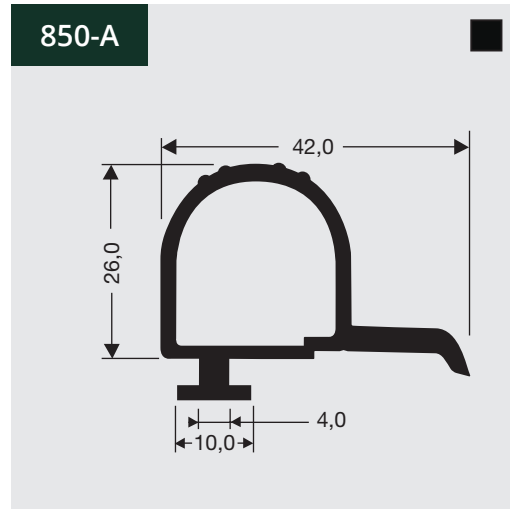
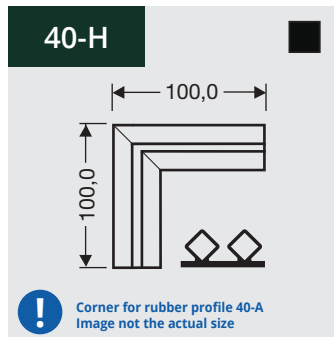
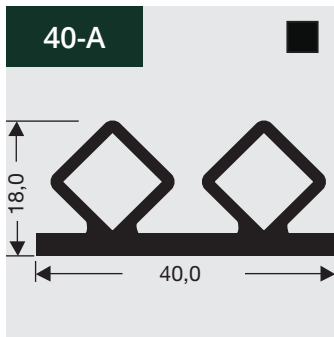
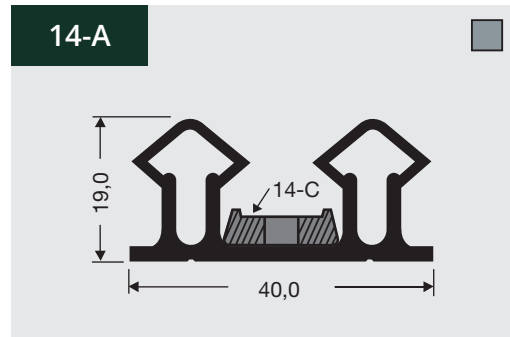
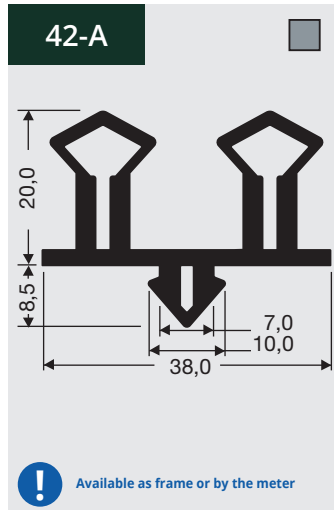
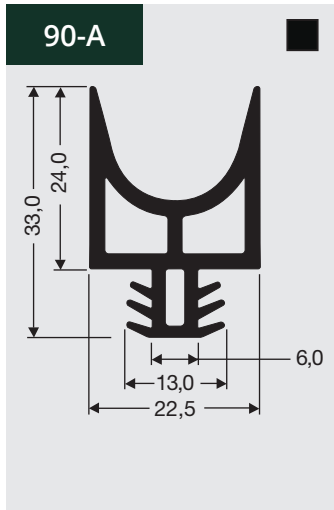

# 10

**Rubber profiles**  
Available on a coil or  
by the meter.

**49-A** ■

38,0

25,0

49-C

! Available per profile length of 210 cm

**49-B** ■

41,0

30,0

49-D

35,5

! Available per profile length of 5 meters

**49-H** ■

100,0

100,0

! Corner for rubber profile 49-B  
Image not the actual size

**53-A** □

20,0

17,0

10,0

**851-A** ■

35,0

26,0

19,0

6,0

800-C

**852-A** ■

37,0

25,0

19,0

5,0

800-C

**894-A** ■

23,0

19,0

12,5

4,5



# 10

Rubber profiles  
Available on a coil or  
by the meter.

**701-A** 

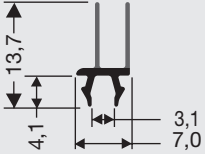

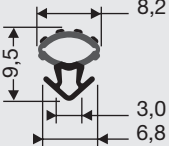

**!** Available per profile length of 1 meter

**702-A** 

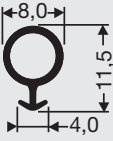

**703-A** 



**704-A** 

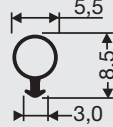

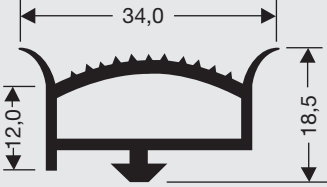

**893-A** 

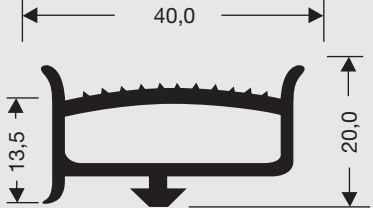

**854-A** 



**57-A** 



**!** Available per profile length of 4 meters

**41-A** 

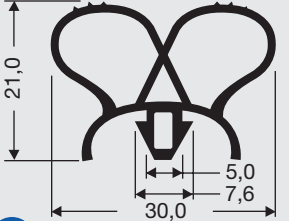

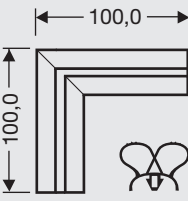

**!** Available as frame or by the meter

**41-H** 



**!** Corner for rubber profile 41-A  
Image not the actual size

**57-B** 



**!** Available per profile length of 4 meters

Copyright 2022 DSU BV  
September 2022

### I-Model

article	a	b
<b>3-60</b>	3 mm	60 mm
<b>3-80</b>	3 mm	80 mm
<b>3-100</b>	3 mm	100 mm
<b>3-150</b>	3 mm	150 mm
<b>3-200</b>	3 mm	200 mm

### L-Model

article	a	b	c
<b>L2-41</b>	2 mm	41 mm	4 mm
<b>L2-45</b>	2 mm	45 mm	4 mm
<b>L2-65</b>	2 mm	65 mm	4 mm

### P-Model

article	a	b
<b>1035</b>	10 mm	35 mm
<b>1735</b>	17 mm	35 mm

### T-Model

article	a	b
<b>T-1246</b>	12 mm	46 mm
<b>T-1466</b>	14 mm	66 mm
<b>T-635</b>	6 mm	35 mm



# 11

## Rubber sweeper profiles

Available on a coil or by the meter.

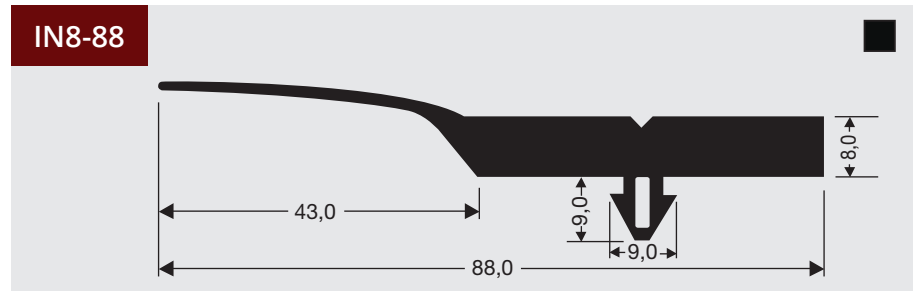
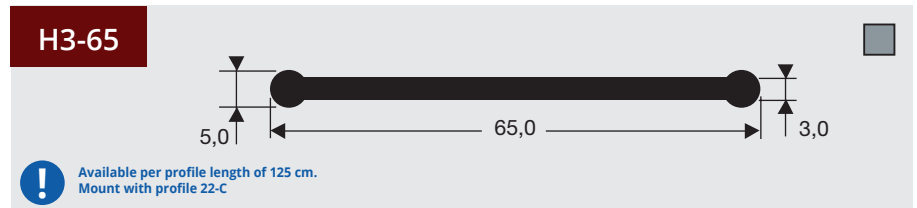
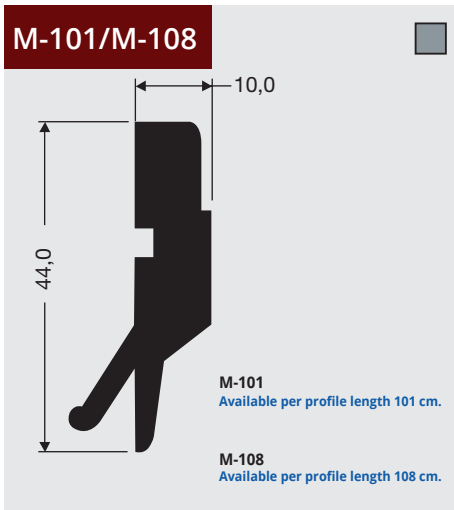
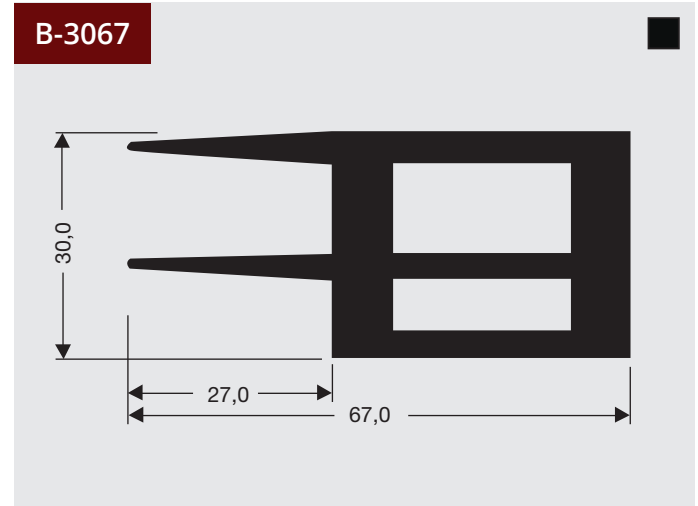
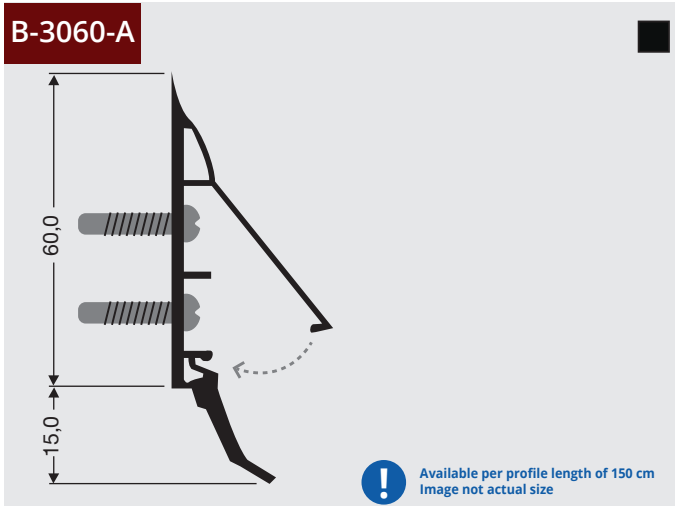



# 11

**Rubber sweeper profiles**  
Available on a coil or by the meter.

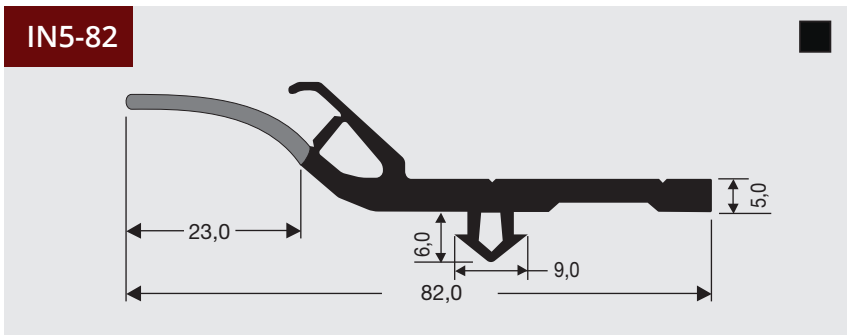
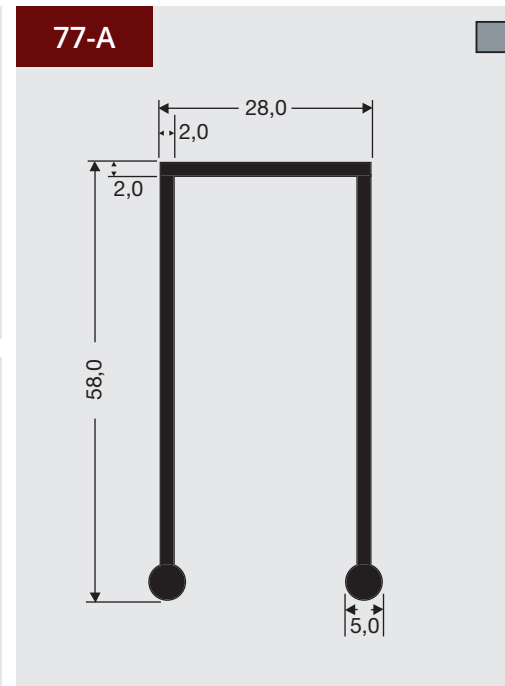
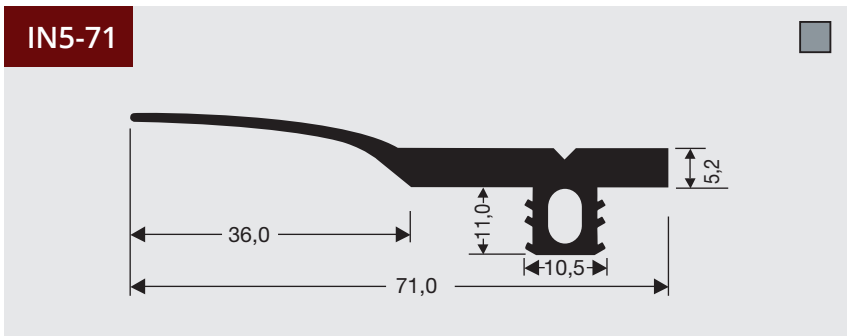
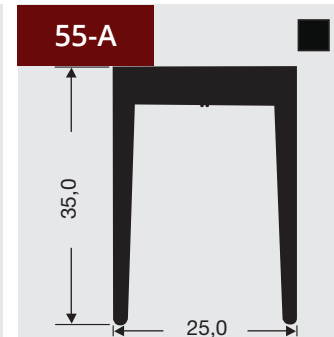
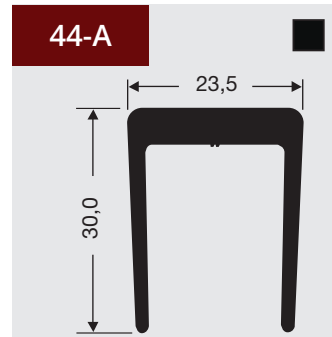
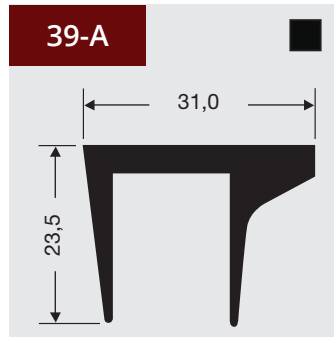
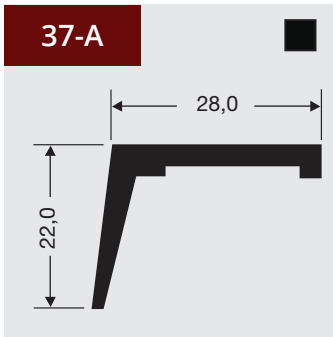



# 12

## EPDM: Neoprene sponge rubber and foam profiles

Available on a coil or by the meter.

EPDM

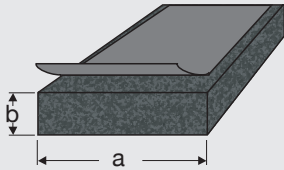

article	a	b
3010	30 mm	10 mm
3015	30 mm	15 mm
4005	40 mm	5 mm
4008	40 mm	8 mm
4010	40 mm	10 mm
4510	45 mm	10 mm
5515	55 mm	15 mm
7515	75 mm	15 mm

 1 side adhesive  
Available in coils of 5 and 10 meters

109

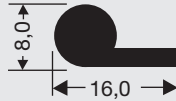

118

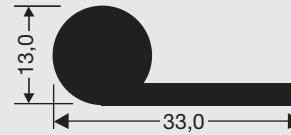

110

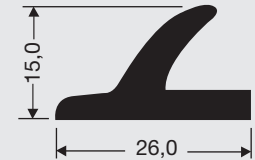

112

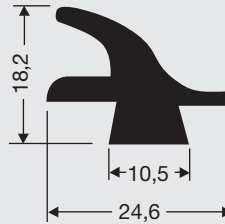

114

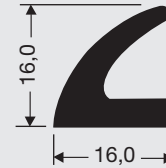

116

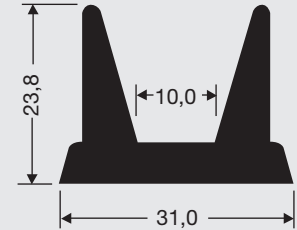

Visit our website for all profiles and quotations

[www.dsu-nl.com](http://www.dsu-nl.com)

**14-C** 

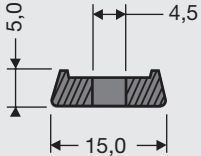

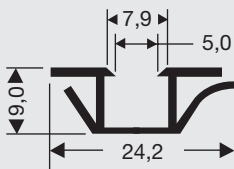

**!** Retainingstrip for profile 14-A  
Available per profile length of 125 cm

**20-C** 



**!** Retainingstrip for dart profiles  
Available per profile length of 211 cm

**22-C** 



**!** Retainingstrip for profile H3-65  
Available per profile length of 118 cm

**26-C** 

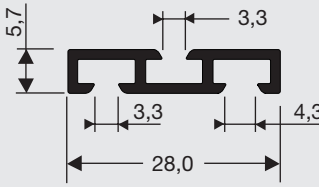

**!** Retainingstrip for dart profiles  
Available per profile length of 125 cm

**43-C** 

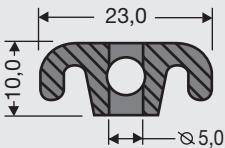

**!** Retainingstrip for profiles 43-A20/28/36  
Available per profile length of 125 cm

**43-D** 

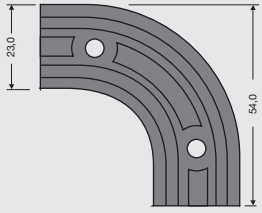

**!** Retainingstrip for profiles 43-A20/28/36  
Image not the actual size

**49-C** 

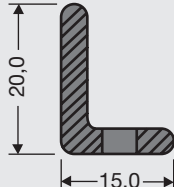

**!** Retainingstrip for profile 49-A  
Available per profile length of 170 cm

**49-D** 

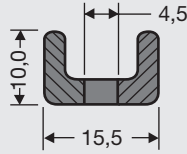

**!** Retainingstrip for profile 49-B  
Available per profile length of 125 cm

**500-C** 

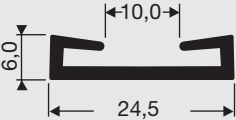

**!** Retainingstrip for profiles 500-A/500-M  
Available per profile length of 200 cm

**800-C** 

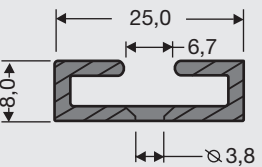

**!** Retainingstrip for profiles 851-A/852-A  
Available per profile length 200 cm

**S-4x13** 

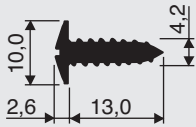

**!** Bag with 20 screws for installing flap profiles

Visit our website for all profiles and quotations

[www.dsu-nl.com](http://www.dsu-nl.com)



Magnet	Article	b mm	a mm	polarity
	M-76	8,0	3,0	sns
	C-76	8,0	3,0	nsn
	M-15	8,0	3,5	sns
	M-25	8,9	2,7	sns
	C-25	8,9	2,7	nsn
	B-25	9,4	2,5	ns
	M-18	10,7	2,5	sns
	C-18	10,7	2,5	nsn
	B-18	10,7	2,5	ns
	M-71	11,8	3,0	sns
	C-71	11,8	3,0	nsn
	M-65	8,0	2,0	sns
	M-66	9,0	2,0	sns
	C-66	9,6	2,0	nsn
	C-79	9,0	2,0	nsn
C-24	9,5	2,4/1,4	nsn	
B-72	12,0	3,4	ns	
C-12	12,5	1,4	nsn	
M-72	15,3	3,3	sns	
<b>Extra strong magnets</b>				
	MS-18	10,7	2,5	ns
	MS-20	9,6	2,7	sns
	MS-25	8,9	2,7	sns
	CS-20	9,6	2,7	nsn

An extra strong magnetic strip provides a 30 - 40% higher force of attraction compared to a regular magnetic strip. Often used in refrigeration where doors or drawers spring open too easily when closing and for refrigeration equipment in moving vehicles. If an extra strong magnet is available, this option is shown in the seal configurator on the website.

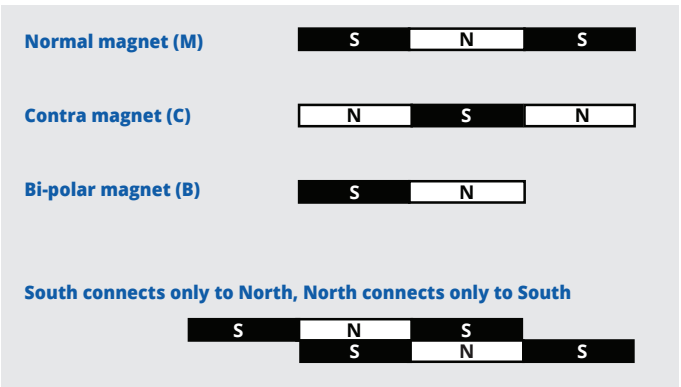

**Functioning of a magnetic strip in a refrigerator seal/gasket**

DSU is using more than 20 different magnetic strips in the production of refrigerator gaskets. The magnetic strips are without exception a combination of north and south poles magnet.

**M - magnet**

Magnet with the letter M is a magnetic strip with the combination South-North-South, this is the most commonly used magnetic strip for refrigerator gaskets.

**C - magnet**

Magnet with the letter C is a magnetic strip with the combination North-South-North, we call this a “contra” magnet. The M – magnet and C – magnet will attract each other.

**B - magnet**

Magnet with the letter B is bi-polar (2-poles) magnetic strip. This type of magnetic strip is only rarely used in refrigerator seals. When a bi-polar magnet is applied it is important to check and test which pole needs to be positioned on the inside and which pole on the outside.

www.dsu-nl.com

**DSU** Catalog - Search by brand - Help - Downloads - About us - Contact  +31 413 - 26 44 72 [My basket](#)

Specialist in commercial fridge & freezer seals

Search for profile number, product or manufacturer

<b>DART PROFILES</b> 	<b>FLAP PROFILES</b> 	<b>LIP PROFILES</b> 	<b>COMPRESSION PROFILES</b> 	<b>RUBBER PROFILES</b> 
<b>SILICONE PROFILES</b> 	<b>EPDM: NEOPRENE SPONGE RUBBER AND FOAM PROFILES</b> 	<b>MAGNETS AND RETAINING STRIPS</b> 	<b>CLEANER, GLUES AND TOOLS</b> 	<b>SEARCH BRAND</b> <input type="text" value="Type brand name"/>

**In-house production** **Extensive product range** **+1 Order from 1 piece** **Always a fitting solution** **Profile selection support** **delivery**

### How to order

Order a replacement seal in four steps:

# Afinox

## Afinox fridge door seal or drawer seal

Fridge seal profiles applied in Afinox professional catering and foodservice refrigeration equipment:



132-M

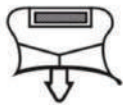

Calculate price

25-M



Calculate price

70-M



Calculate price

73-M



Calculate price

### Other

Profile not found?



Send us a picture

Identify profile

Identify the seal profile of Afinox refrigeration equipment.

Replace a fridge or freezer door seal in 4 steps.

### About Afinox

Afinox is an Italian producer of professional refrigeration equipment for the hospitality and catering sector.

### OTHER BRANDS

Brands overview

- [Aber](#)
- [Accona](#)
- [Aemmegel](#)
- [Afinox](#)
- [Ahmet Yar](#)
- [AHT](#)
- [Aichinger](#)
- [AIFO](#)
- [AKE](#)
- [Alaska](#)
- [Alba Horovice](#)
- [Alcold](#)
- [Alinox](#)
- [Alluserv](#)
- [Almaco](#)
- [Alnox](#)
- [Alpeninox](#)
- [Alpfrigo](#)
- [Aluminox](#)
- [Ambach](#)
- [American Panel](#)
- [Ameristar](#)
- [Amitek](#)
- [Angelo Po](#)
- [Anthony](#)
- [ARCO](#)
- [Arctic Air](#)
- [Arctica](#)
- [Ardco](#)

**Find the profiles used per brand via "search by brand" on our website**

# 132-M

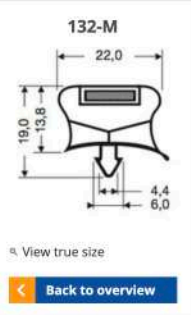

**Composition**

4 sides - 4x magnet

Strong magnet

**Measurement method**

A size (Outside-to-Outside)

C size (Dart-to-Dart)

**Color**

**Measurements**

short side  
38.3 cm

long side  
62.4 cm

**Reference**

Polaris prep counter

**Summary**

**132-M**

- 4 sides - 4x magnet
- C size (Dart-to-Dart)
- Grey
- 62.4 cm x 38.3 cm (length x width)

Per piece	EUR 0,00
Quantity	2
Sub total	EUR 0,00
Total amount	EUR 0,00

Add to cart

Quantity

Collective discount

In-house production Extensive product range +1 Order from 1 piece Always a fitting solution Profile selection support Fast delivery

## Do you need help?

We are happy to help



WhatsApp

+31 6 30 50 3000



FAQ

Frequently asked questions



Identify profile

Upload your profile here



Call us

+31 413 26 44 72



Mail us

sales@dsu-nl.com

Instant price quote for a fridge seal with our online seal configurator

## DSU Sales UK & Ireland

☎ 0330 027 1648

## DSU Production

Neutronenlaan 1  
5405 NG Uden  
The Netherlands

☎ +31 413 264 472

✉ sales@dsu-nl.com

🌐 www.dsu-nl.com

📞 +31 6 30 50 3000

WhatsApp



**DSU are UK VAT registered. We pay the VAT directly to HMRC which ensures a smooth delivery process.**



**DSU**